



**FOOD PUMPS
AND SYSTEMS
CATALOGUE**

#2019

www.pcm.eu



FLUID HANDLING EXPERT IN THE FOOD INDUSTRY

PCM is a leading manufacturer of pumping, dosing, mixing and filling systems for the food industry.

» END-TO-END PRODUCT INTEGRITY

Today's high quality foodstuffs are made with highly expensive ingredients. And the market trend is towards more recognisable processed foods with whole vegetables and fruits. Our systems enable you to handle - transfer, dose, mix and fill - challenging ingredients with minimal damage.

» LOW LIFE CYCLE COSTS

A pump that is not well adapted to its operational parameters can cost you money in terms of production, maintenance downtime and energy consumption. We use Life Cycle Costs (LCC) analysis to find the most cost-effective pumping solutions for your industrial processes.

» PERFORMANCE YOU CAN COUNT ON

Reliability and productivity are your best allies in facing the non-stop nature of today's just-in-time retail supply chain. PCM pumping, dosing, mixing and filling systems enable you to produce the same recipe identically from the start of your production run until the finish and ensure repeatability.

» MEETING THE STRICTEST STANDARDS

We share your commitment to ensuring customer safety. To begin with, all our systems are CIP (Cleanable In Place). In addition, we continually invest in innovations that enable you to anticipate constantly evolving food safety regulations. Finally, our vast international experience enables us to design systems that meet both local regulations and international standards.

» OUR MARKETS



1930
René Moineau invents the Progressing Cavity Pump (PCP).



1932
René Moineau, in partnership with Robert Bienaimé, founded PCM Pompes



1970
PCM invests beyond the Progressing Cavity Pump and adds Delasco™ and Precipompe™ to its product range.

1990
PCM acquires Dosys™ technology and develops its range of systems

2009
PCM introduces the PCM Dosymix™ dynamic mixer, 3A certified.



2012
PCM launches two new products in the food market: the EcoMoineau™ C PCP and the HyCare™ hygienic PCP.



2015
Dosys™ pump (DACC) acquires 3A certification.





2018
PCM launches its PCM Dosymix™ mixer with buffer hopper

FOOD CONTACT AND HYGIENIC DESIGN

It is important to understand the difference between these two concepts, both of which are involved in controlling food safety.



FOOD CONTACT

These symbols  for the European Union and  for United States ensure **compliant materials** are safe according to regulatory requirements.

These requirements show that, under normal and foreseeable conditions of use, these materials do not transfer their constituents to food in a quantity likely:

- to present a danger to human health,
- to cause an unacceptable change in food,
- to cause a deterioration in the organoleptic characteristics.

HYGIENIC DESIGN

 certifications for the European Union and  for the United States define criteria for **hygienic design and cleanability** for equipment production.

Their recommendations are intended to remove all retention areas likely to promote bacterial or microbial growth and may include:

- geometry of equipment
- surface roughness
- manufacturing methods (welding...).

Both organisations share common goals: process non-contamination and food safety.

CFD TO PROMOTE HYGIENE

The use of CFD (Computational Fluid Dynamics) nowadays is a very powerful and robust tool to model phenomena related to fluids.

Numerical simulations, carried out in the PCM R&D department, allow computing the flow field through the volumetric pumps manufactured by PCM. These calculations have allowed PCM to optimise the internal design of pumps and **improve the cleaning in place effect**. This result was obtained by increasing the speed of the cleaning fluid and by studying the turbulences in the most difficult areas to clean.

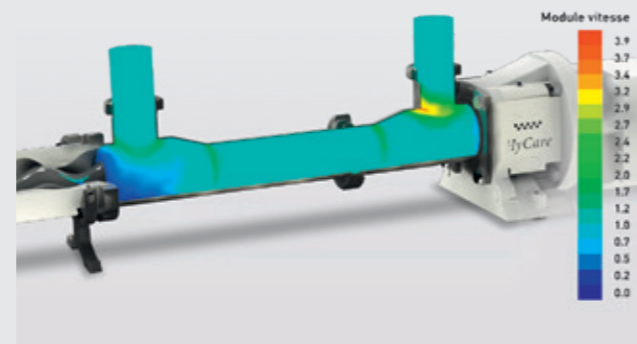

Cleaning-in-place (CIP) fluid speeds modelling in the body of the HyCare™ pump using CFD.



TABLE OF CONTENTS

PCM TECHNOLOGIES	6
<ul style="list-style-type: none"> • PCM Moineau™ progressing cavity pumps • PCM Dosys™ piston and valve pumps • PCM Delasco™ peristaltic pumps • PCM Lagoa/MDS diaphragm dosing pumps 	<ul style="list-style-type: none"> 6 7 8 9
PCM FOOD OFFER	10
Transfer	16
<ul style="list-style-type: none"> • PCM HyCare™ • PCM EcoMoineau™ C • PCM EcoMoineau™ C with floating stator • PCM IVA/LVA/GVA • PCM Delasco™ DL 	<ul style="list-style-type: none"> 18 22 26 28 32
Injection and dosing	36
<ul style="list-style-type: none"> • PCM Dosyfruit™ Premium • PCM Dosyfruit™ Basic • PCM Hopper Station • PCM Dosing Unit • PCM Additive Station • PCM Lagoa 	<ul style="list-style-type: none"> 40 41 42 43 44 45
Mixing	46
<ul style="list-style-type: none"> • PCM Dosymix™ • PCM Dosymix™ with buffer hopper • PCM Dostam 	<ul style="list-style-type: none"> 48 52 54
Filling	58
<ul style="list-style-type: none"> • PCM Dosyfill • PCM Additivefill 	<ul style="list-style-type: none"> 60 62
Feeding	64
<ul style="list-style-type: none"> • PCM Dosyfeed & PCM Additivefeed 	66
Topping	68
<ul style="list-style-type: none"> • PCM Dosytop 	70
Combination / multi-functions	72
PCM SERVICES	74

PCM MOINEAU™ TECHNOLOGY

Progressing cavity pumps

From the name of the inventor and PCM co-founder: René Moineau

MOINEAU™ TECHNOLOGY PRINCIPLE

A Moineau™ pump consists of a helical rotor turning in a helical stator. When the rotor turns inside the stator, the honeycomb progresses spirally along the axis of the pump without changing either shape or volume. This action transfers the product from the pump suction to the pump discharge without degrading the product.

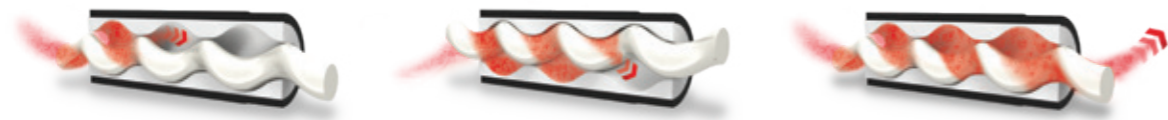

BENEFITS

- Preserves the texture of fragile fluids (no shearing compared with lobe or ECP technologies)
- Handles fluids with solids
- High suction capability
- Self-priming (negative head compatible)
- Constant non-pulsating flow
- Reversible

MAIN APPLICATIONS

- Transfer of fragile and/or viscous liquid products
- Dosing of fragile and/or viscous liquid products

PCM DOSYS™ TECHNOLOGY

Piston and controlled valve pumps

The keys of a perfect dosing and filling

DOSYS™ TECHNOLOGY PRINCIPLE

Dosys™ pump technology sits at the heart of all PCM systems. Invented by PCM, it makes it feasible to replace wasteful systems with highly accurate and efficient inline injection.

Dosys™ pump automatically synchronises dosing volumes with the filling station for optimal performance. It also meters the ingredients with precision, thanks to servo-driven piston and a patented flow-control valve. Dosys™ pumps are designed to handle liquids, semi-solids and viscous products without degrading their texture.

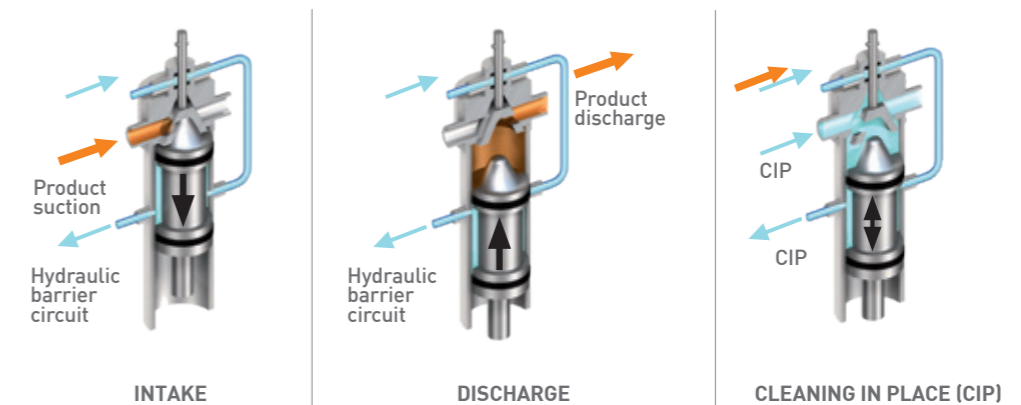

BENEFITS

- It meters the ingredients with precision (repeatability: 0.5%)
- Dosys™ pumps handle ingredients with large semi-solids (up to 48 mm / 1.89 inch.) without damaging them
- Because there is no rotating movement, solids remain suspended in the liquid medium; no emulsion or aeration is created
- Dosys™ pumps can be cleaned in place (CIP/SIP)

MAIN APPLICATIONS

- Inline injection of ingredients
- Filling of various ingredients in any type of containers
- Dosing for heterogeneous and/or viscous ingredients stuffing

PCM DELASCO™ TECHNOLOGY

Peristaltic pumps

The ideal choice to reduce maintenance costs

› DELASCO™ TECHNOLOGY PRINCIPLE

The peristaltic pumping principle is based on the capacity of a soft elastomer hose to accept a deformation and subsequently recover its initial shape. Peristaltic pumps are provided with either high or low pressure hoses, covering a wide range of applications which need versatility and flexibility.

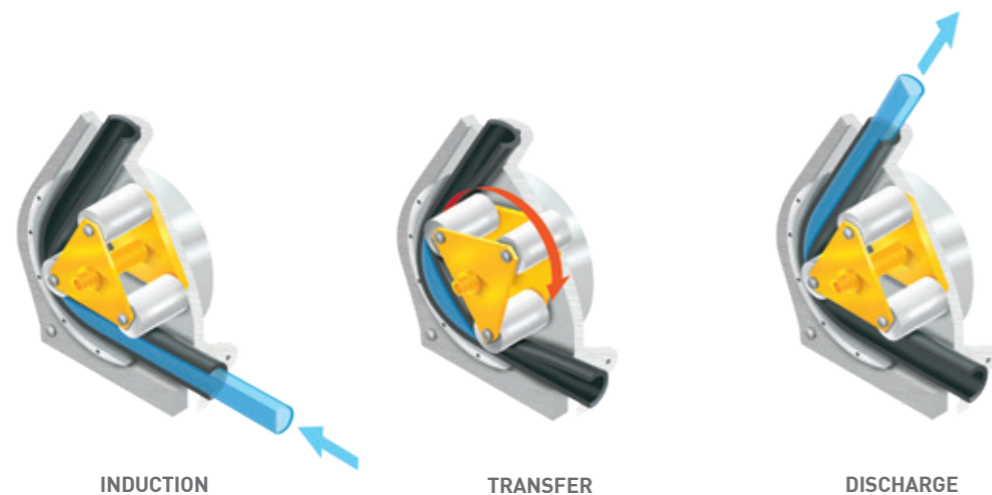

› BENEFITS

- Only one wearing part: the hose
- Seal-less design
- Self-priming
- High suction capacity
- Simplified maintenance
- Low life cycle costs
- No mechanical seals, valves or gaskets

› MAIN APPLICATIONS

- Transfer of high abrasive or corrosive ingredients

PCM LAGOA™ TECHNOLOGY

Diaphragm and MDS metering pumps (synchronized multi-pumphead)

Accuracy and reliability: ingredients of successful dosing

› LAGOA™ TECHNOLOGY PRINCIPLE

The Lagoa pump is composed of a diaphragm connected to a piston which alternating movement successively fills and empties the pumphead.

› MDS TECHNOLOGY PRINCIPLE

The MDS dosing units consist of several membrane dosing heads.

The dosing heads are equipped with needle valves at the inlet and ball valves at the outlet.

Each diaphragm stroke is adjusted by a micrometer screw allowing a customized dosage. A rotary cylinder drives shafts equipped with eccentrics, which are fixed so that the diaphragms move synchronously.

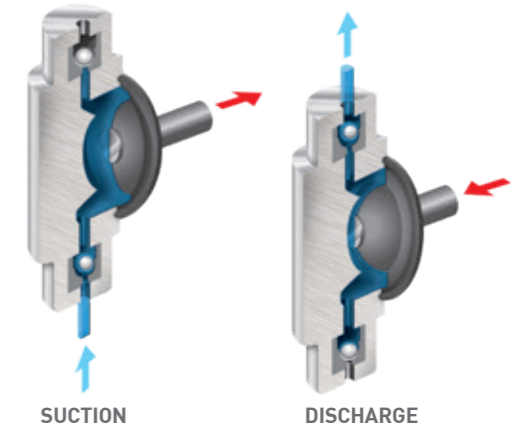

› BENEFITS

- Reliability of metering
- Simplified maintenance
- Dry-running
- Simple and robust

› MAIN APPLICATIONS

- Dosing of liquid products (additives, colourings,...)
- Dosing of cleaning products (acid, soda, detergents, ...)
- Synchronized multi-dosing of flavours in pots (sirup, fruit flavour, ...)
- Synchronized multi-dosing of liquid ingredients for various preparation feeding

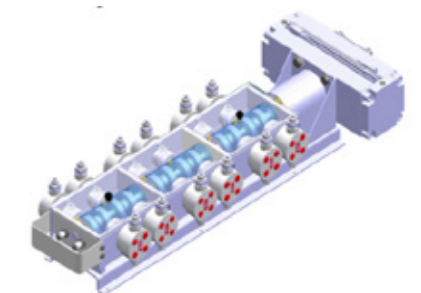

Synchronized multi-pumphead (MDS)

A PCM SOLUTION

all along your manufacturing process

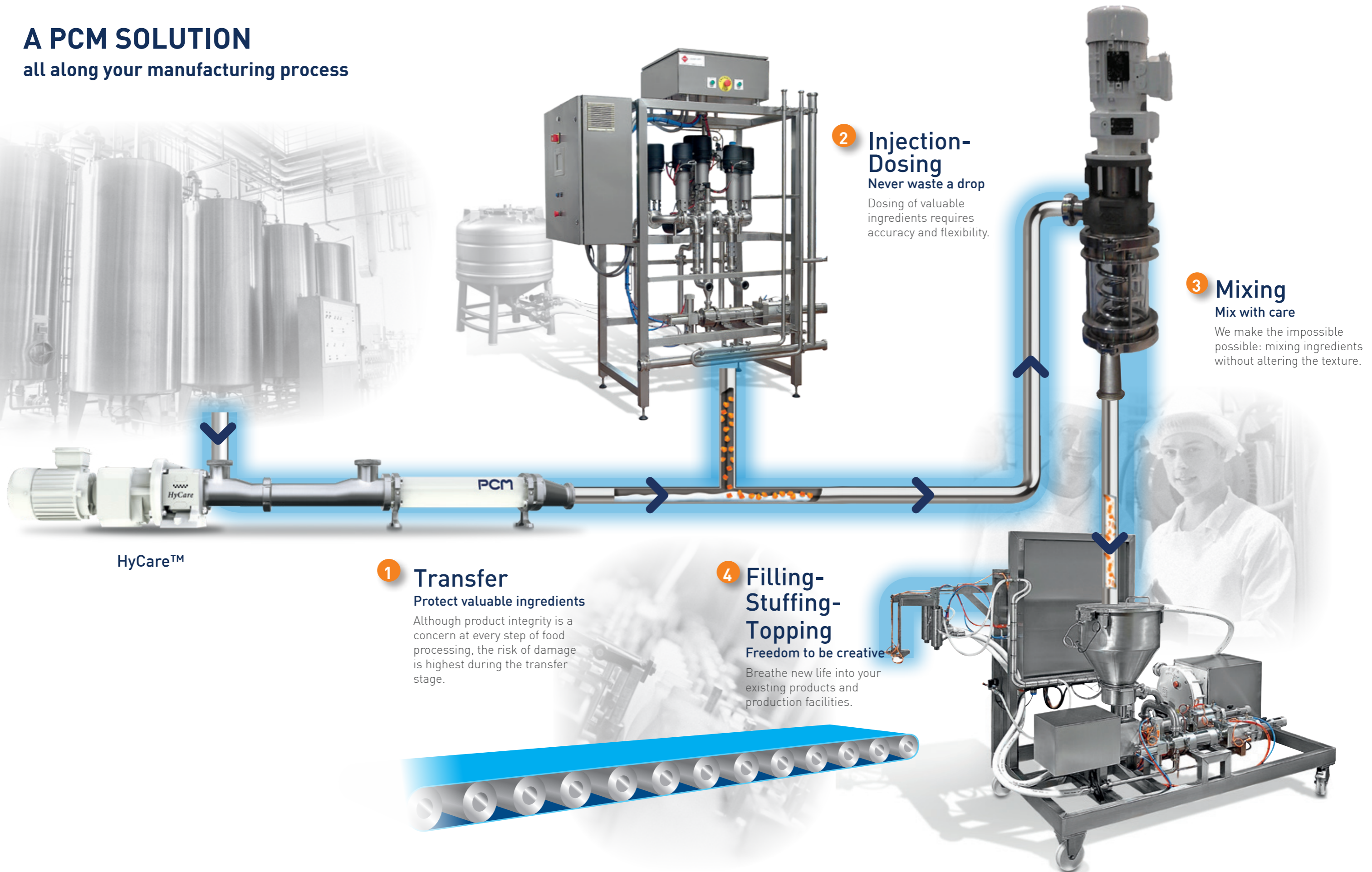

HyCare™

1 Transfer
Protect valuable ingredients
 Although product integrity is a concern at every step of food processing, the risk of damage is highest during the transfer stage.

4 Filling-Stuffing-Topping
Freedom to be creative
 Breathe new life into your existing products and production facilities.

2 Injection-Dosing
Never waste a drop
 Dosing of valuable ingredients requires accuracy and flexibility.

3 Mixing
Mix with care
 We make the impossible possible: mixing ingredients without altering the texture.

A PCM SOLUTION

all along your manufacturing process

RAW INGREDIENT TRANSFER



TRANSFER

FRAGILE PRODUCTS



- Hygienic progressing cavity pump
PCM HyCare™ (p.18)
- Progressing cavity pump
PCM EcoMoineau™ C (p.22)

VISCOUS PRODUCTS



- Hopper progressing cavity pump
PCM IVA-GVA (p.28)

ABRASIVE PRODUCTS



- Peristaltic pump
PCM Delasco™ DL Series (p.32)

RECIPE PROCESSING



INJECTION / DOSING

HETEROGENEOUS PRODUCTS WITH VACUUM SUCTION



- Multi ingredients dosing system
PCM Dosyfruit™ (p.40)
PCM Dosing Unit (p.43)

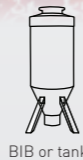

HETEROGENEOUS PRODUCTS WITHOUT VACUUM SUCTION



- Hopper dosing system
PCM Hopper station (p.42)
PCM Dosing Unit (p.43)

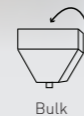

LIQUID PRODUCTS - AROMAS AND ADDITIVES



- Additive dosing system
PCM Additive station (p.44)

MIXING

HETEROGENEOUS AND/OR FRAGILE PRODUCTS



- Inline dynamic mixer
PCM Dosymix™ (p.48)

LIQUID HOMOGENEOUS PRODUCTS WITHOUT PARTICLES



- Inline static mixer
PCM Dostam (p.54)

FINAL PROCESSING

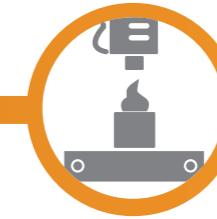

FILLING

DIVERSE PRODUCTS ALL PACKAGING



- Filling system
PCM Dosyfill (p.60)

LIQUID PRODUCTS SMALL DOSES ALL PACKAGING



- Filling system
PCM Additivefill (p.62)

STUFFING

HETEROGENEOUS OR VISCOUS PRODUCTS



- Needle stinging system
PCM Dosyfeed (p.66)

LIQUID PRODUCTS

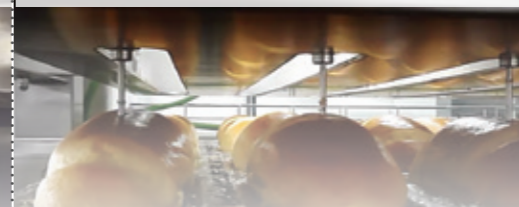

- Needle stinging system
PCM Additivefeed (p.66)

TOPPING

VISCOUS PRODUCTS



- Topping system
PCM Dosytop (p.70)

CHOOSE YOUR APPLICATION AND BUILD YOUR OWN!

PCM studies your needs and proposes solutions adapted to your constraints by combining these systems.

Examples:

- Stirred fruits yoghurts: PCM HyCare™ + PCM Dosyfruit™ + PCM Dosymix™ + PCM Dosyfill
- Vanilla set yoghurts: PCM HyCare™ + PCM Additive station + PCM Dostam + PCM Dosyfill
- Caramel stuffed rolls: PCM Dosing Unit + PCM Dosyfeed multi-heads

A PCM SOLUTION

all along your manufacturing process



› DAIRY



› MEAT, FISH, PETFOOD



› BAKERY



› SUGAR & STARCHES



› CONVENIENCE FOOD



› FRUITS & VEGETABLES



› COSMETICS



› DRINKS

TRANSFER	Various white mass, Cream, Matured milk, Curd, Butter, Melted cheese, Ricotta cheese	Mechanically separated meat (MSM), Blood, Animals fat, Offals / carcass, Gelatin, Liquid eggs, byproducts (ground meat)	Liquid batter, Batter/premix, Cream, Liquid eggs	Molasses, Beetroot pulp or juice, Chocolate, Honey, Caramel, Byproducts
INJECTION DOSING	Liquid aromas, Fruits preparation, Rennet and liquid ferments, Vitamins, Probiotics	Blood, Animals fat, Colourings, Liquid antioxidant, Fish oil, Gelatin	Water, Liquid aromas or colourings, Alcohol, liquor, Liquid eggs, Cream, Chocolate, Jam	Liquid aromas or colourings, Sugar syrup, Lecithin (for chewing gum), Glycerin, PGPR*, Gelatin
MIXING	Stirred fruit yoghurt, Aroma for flavoured milk + liquid starch (1 ingredient of transfer + 1 injection ingredient)	Meat preparation + colours, Petfood + antioxidant (1 ingredient of transfer + 1 injection ingredient)	Liquid batter + cream (1 ingredient of transfer + 1 injection ingredient)	Marshmallows + colourings, Chocolate + liquor (1 ingredient of transfer + 1 injection ingredient)
FILLING	All types of yogurts, Dessert Creams, Bottom layer in cup (multilayer), Cream in 10L bucket, Co-dosing (2 products side by side in a single cup), Rennet in the bottom of cups	Minced meat in bag, Terrines, Lard in pots, Multilayered fish terrines	Cake batter in baking molds	-
STUFFING	-	Gelatin in terrines	Jam in rolls, Aromas in pastries, Chocolate/caramel in pancakes, Cream in profiteroles	-
TOPPING	Jam on the top of yoghurt	Hot liquid jelly on patties, Lard, Crumb of chicken or tuna in paste on sandwiches	Chocolate, Jam, Caramel, Honey, Cake icing, In line topping of custard on pastries	-

* Polyglycerol polyricinoleate

TRANSFER	Preparation in sauce, mashed potatoes, Vegetables, Oils, Mustard, Ketchup, Mayonnaise	Compote, Jam, Concentrated tomatoes, bunch of grapes raisin, Almond paste, Alginate, Pea fiber, Byproducts (peelings)	Mascara, Shampoo, Toothpaste, Thermal clay sludges	Fruit juice, Concentrated fruit or vegetables juice, Fermented must, Wine
INJECTION DOSING	Sauce, Cream, Liquid aromas	Liquid sugar, Pectin, Lemon juice, Liquid colourings, probiotics	Vitamins, Oil, Water, Liquid aromas	Gum arabic, Syrup, Liquid aromas or colourings, ferments, Alginate balls
MIXING	Vinaigrette, Mayonnaise base + starch, Ketchup + pickles	Spinach + cream (1 ingredient of transfer + 1 injection ingredient)	Shower gel + purified water (1 ingredient of transfer + 1 injection ingredient)	Clear wine + sugar musts, water + syrup (1 ingredient of transfer + 1 injection ingredient)
FILLING	Ready made meals, Lasagnas in a tray, vegetables in sauce, Soups, Sauces (Individual or in pouches), Mayonnaise, Baby food (steamed process)	Apple sauce in cup, Canned fruit salad, Peach quarters in syrup in 3L can, Baked beans in can	Lotions (little bottles), Gel, Toothpaste (tube), Clay in tube or bucket, Peeling, Cosmetic cream, Lipstick	-
STUFFING	Gelatin in terrines	-	-	-
TOPPING	Cream, Coulis, Cornish pasties, Vinaigrette on salad, Various sauces (bolognaise, béchamel)	-	Self-tanning topping on gloves, Wipe topping with lotion cleansing	-

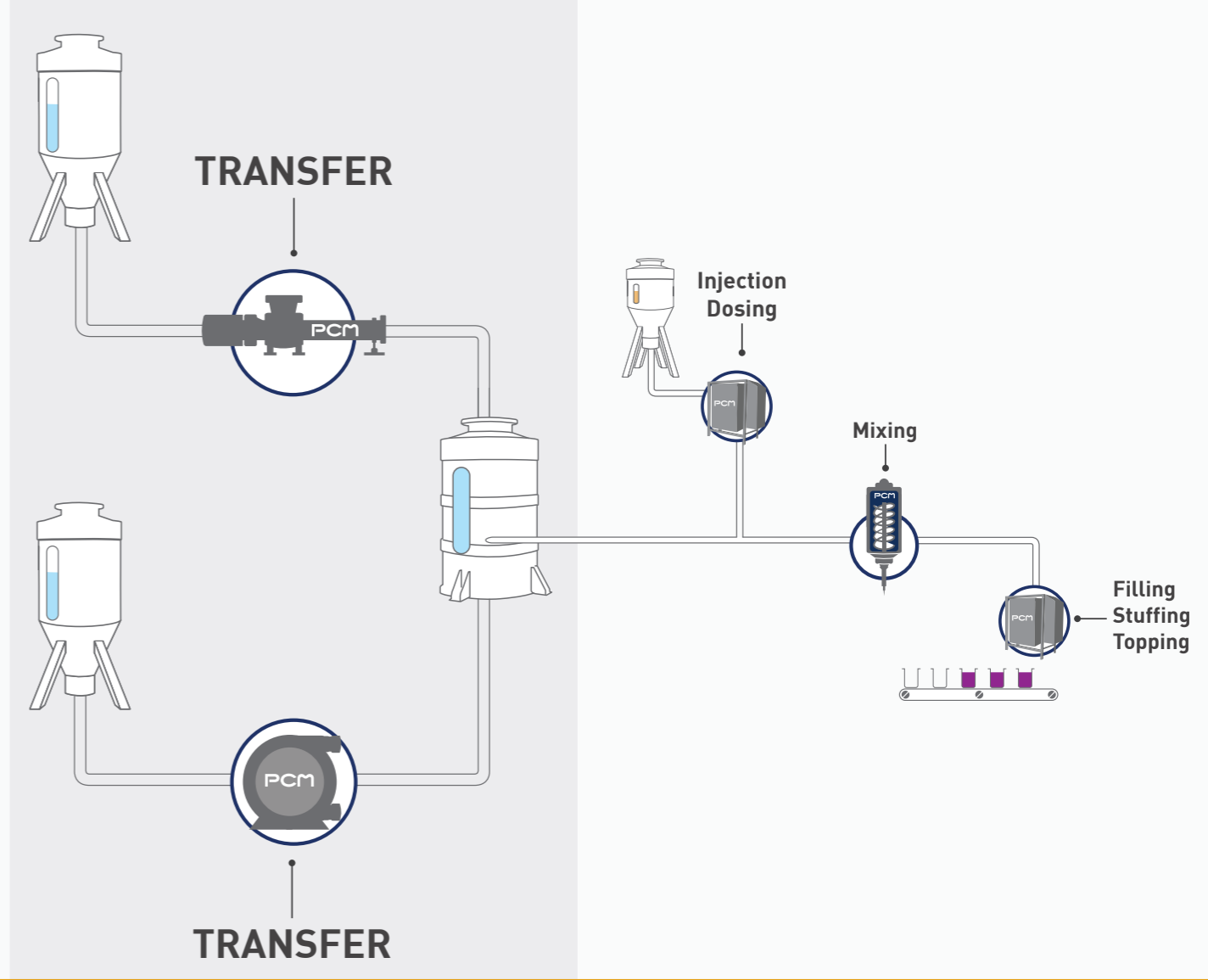

TRANSFER

Protect valuable ingredients: no ingredient is too complex

PCM transfer solutions are the ideal choice for pumping a wide range of ingredients from thin liquid to highly viscous pastes and sauces, at cold and hot temperature. These ingredients can be sticky, slippery or contain solids (including large chunks and soft pieces such as chopped vegetables and whole fruits). PCM transfer pumps and systems are also recommended for applications that require pressure variations, depression and viscosity variations.

The choice of the technology will depend on the application and its requirements.

PCM Moineau™ progressing cavity pumps range:

- PCM HyCare™
- PCM EcoMoineau™ C
- PCM IVA/LVA/GVA

PCM Delasco™ peristaltic pumps range:

- PCM Delasco™ DL

PCM MOINEAU™ PROGRESSING CAVITY PUMP

Respect the texture of fragile fluids

When you handle fragile products, the risk to the quality and texture of ingredients is highest during this transfer stage and depends partly on the pump technology used.

With Moineau™ technology, PCM is committed to handle your ingredients with the highest level of care, ensuring the integrity and the texture of your products thanks to a controlled and minimum slip rate.

PCM DELASCO™ PERISTALTIC PUMPS

Handle abrasive and corrosive fluids

With only one item in contact with the pumped product and low operating speed, peristaltic pumps are ideal to transfer very abrasive and/or corrosive fluids (musts, ground meat juices with bone fragments...). They are also able to transfer soft or solid pieces without any damage (e.g. peach transfer). Furthermore, they can easily integrate specific industrial processes as occasional dry running is possible without damage occurring.



PCM HYCARE™

Food is obvious, hygienic for more safety!

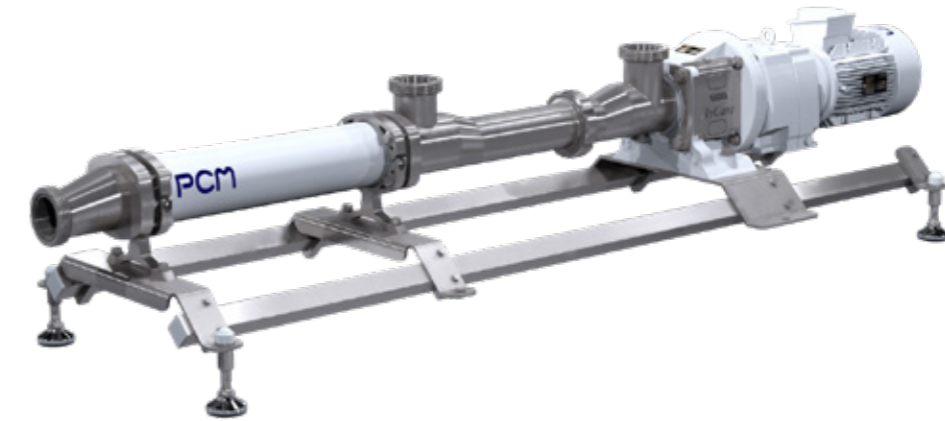

The HyCare™ pump has been designed to meet the strictest food hygiene standards.

EHEDG (Europe) or 3A (USA) certified, this pump has become the **reference for the food industry**.

The HyCare™ pump complies with the **FDA (USA)** and **CE 1935/2004 (Europe)** requirements which guarantee materials compatibility with food products and equipment traceability.

HyCare™ pump technology offers **unbeatable hygiene and food safety**.



TECHNICAL PERFORMANCES

- **Pressure** : 16 bars [232 psi]
- **Flowrate** : 50 m³/h [220 USGPM]
- **Particles size** : 32 mm [1.26 inch.]

RANGE

- 22 models

EXAMPLES OF APPLICATIONS

Designed for microbiologically sensitive food applications:

- Dairy products
- Meat
- Liquid eggs ...

**PCM HYCARE™
CONSTRUCTION AND BENEFITS**

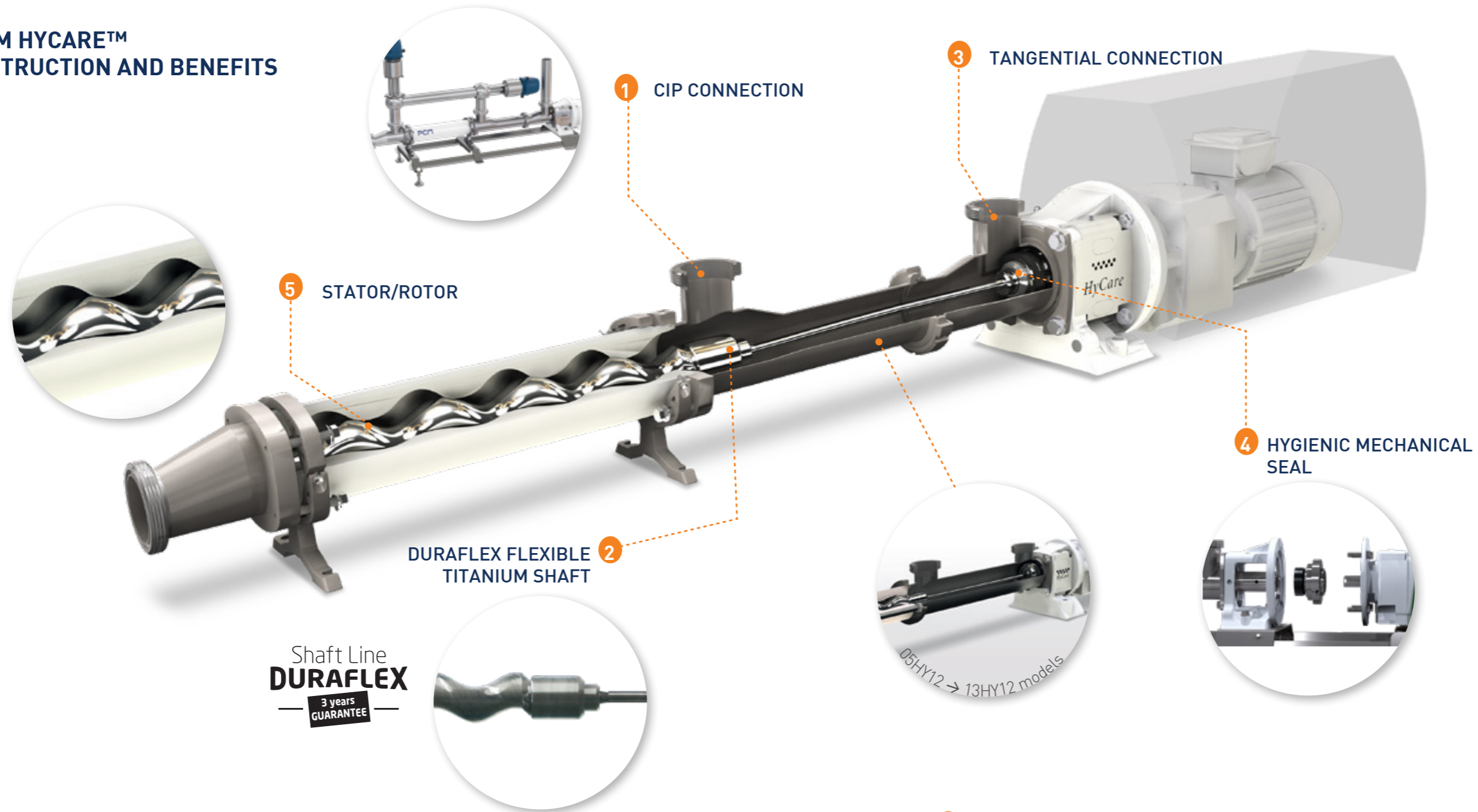

AVAILABLE CONNECTIONS

- SMS
- Clamp (3-A)
- DIN 11851
- Din 11864-1 (3A and EHEDG)

The pump can be provided **with or without** vertical CIP connection.

3 AVAILABLE POSITIONING FOR SUCTION CONNECTIONS

- Upward tangential
- Right tangential*
- Left tangential*

* looking from outlet side towards the drive

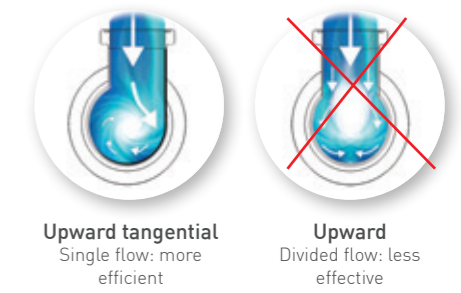

1 CIP CONNECTION

- Designed to be cleaned in place

2 DURAFLEX FLEXIBLE SHAFT

In titanium:

- Quality and reliability
- 3 years guarantee
- The shaft flexibility allows a small footprint

One-piece design :

- Any possible retention area unlike the classic open joints



- The total absence of wear parts prevents any risk of metal particles being released into the product

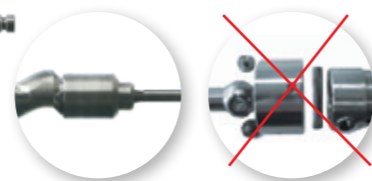

3 OPTIMIZED BODY DESIGN

- The shape and the tangential connection improve cleaning efficiency (internal flow speed)

4 HYGIENIC MECHANICAL SEAL

- Its position near the CIP inlet allows optimum cleaning
- Its internal design is free of screws or springs (any retention area)
- Easy and quick maintenance without disconnecting the pipes

5 MOINEAU™ TECHNOLOGY respects the texture of your pumped products *(learn more p.6)*

6 STATOR ANTI-ROTATION SYSTEM

- Ensures a secured position even in case of high pressure or high temperature

7 BASEFRAME WITH ADJUSTABLE FEET

- From 20 mm to 50 mm [0.79 to 1.97 inch.] according to models



* The warranty is 3 years under normal conditions of use: within the limit of 10 000 operating hours, at a speed between 80 and 280 rpm, in compliance with the PCM CIP guidelines.



PCM ECOMOINEAU™ C

The shortest progressing cavity pump in the market

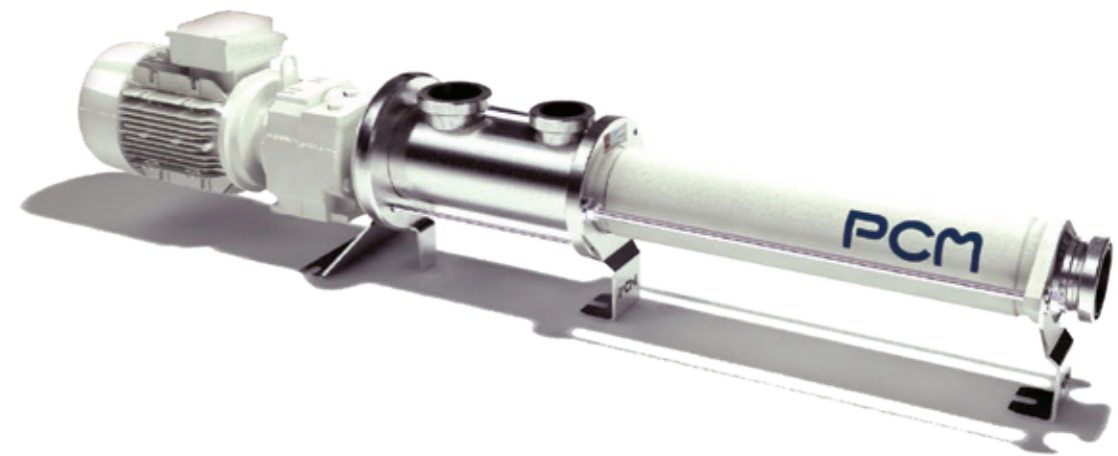

Its revolutionary design combines the legendary performance and reliability of **PCM Progressing Cavity Pumps technology** with a highly modular, eco-friendly design. The EcoMoineau™ C pump requires less space for installation which reduces costs and facilitates its integration.

The EcoMoineau™ C pump is **lighter** (less raw materials) and **uses 10% less power** than most progressing cavity pump on the market. The energy

used to manufacture, transport and operate the EcoMoineau™ C pump is therefore optimised.

This PCP is made with fewer parts compared to competitors models. This new stainless steel pump has **a multitude of design features** that make **installation, operation and servicing easier than ever before.**



TECHNICAL PERFORMANCES

- Pressure : 16 bars [232 psi]
- Flowrate : 110 m³/h [484 USGPM]
- Particles size: 32 mm [1.26 inch.]

RANGE

- 26 models

EXAMPLES OF APPLICATIONS

Recommended for non microbologically sensitive food applications:

- Fruits and vegetables (soup, sauce, jam, puree...)
- Beverages (fruit juice, thick juice, wine, additives,...)
- Glucose, syrups, massecuite, molasses
- Pasteurised preparations
- Grease, oil (colza, olive, ...), enzymes

› PUMP CONSTRUCTION

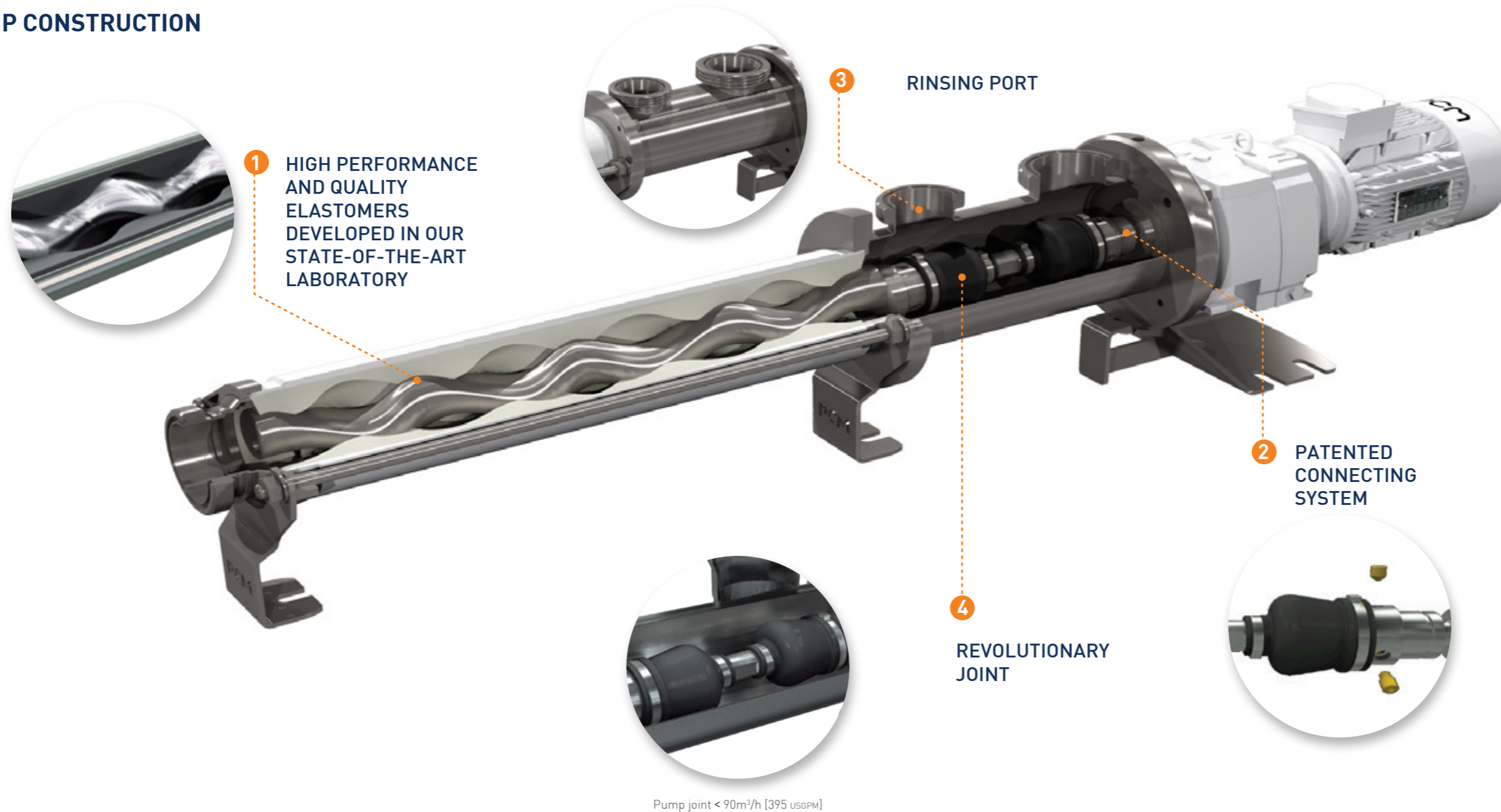

› JOINT ASSEMBLY BENEFITS

- **Cost and stock savings:** same joint assembly for all models from the same module
- **Maintenance time saving:** 3 screws only to dismantle the joint
- **Patented connecting system**
- **Durable and robust design:** lifespan increase for non corrosive and non abrasive applications



› PCM ECOMOINEAU™ C BENEFITS

SPACE SAVING

- Revolutionary joint 80 % shorter
- Revolutionary joint coupling rod length reduced and hardened for long life operation
- Patented connecting system: only 10 cm of clearance required to dismantle the stator

EASY AND QUICK DISMANTLING

- The seal can be changed by simply disconnecting the drive
- The shaft line (rotor, coupling rod, driving shaft) can be removed without disconnecting pipework
- Patented connecting system with 3 screws only

FOOD COMPLIANT

- Food connections and flushing ports
- FDA and European food regulations compliant materials
- Single, double and flush mechanical seals

VERSATILE CONSTRUCTION

Integrated construction

- Cost-effective solution including single bellow mechanical seal (self-positioning)
- Shortest and lightest design

Monobloc and bearing construction

- Five sealing solutions available
- Spacer with improved access to the sealing system
- Rubber deflector: protecting the drive and bearing

ECO-DESIGN PUMP

- 10% less power consumption compared to most Progressing Cavity Pump's on the market
- Less raw materials

PCM ECOMOINEAU™ C WITH FLOATING STATOR

The most compact progressing cavity pump in the market

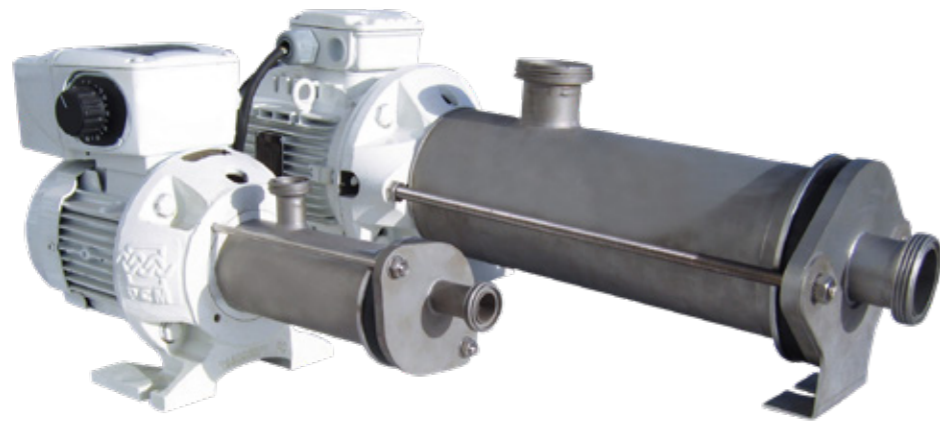

With a high suction capacity, the PCM EcoMoineau™ C progressing cavity pump with floating stator is ideal for transferring a wide range of viscous and non-viscous food fluids.

Its simplified design and compactness allow a quick and cost-efficient maintenance. The flexibility of the floating stator (without frame) allows the rotor to

rotate eccentrically, as the rotor is directly connected to the drive (no connecting rod). This makes the pump body shorter.

The EcoMoineau™ C with floating stator is ideal for small space requirements.



TECHNICAL PERFORMANCES

- **Pressure:** 4 bars [58 psi]
- **Flowrate:** 0.010 up to 6.8 m³/h [0.04 to 29.9 USGPM]
- **Particles size:** 8 mm [0.31 inch.]

RANGE

- 6 models

PUMP CONSTRUCTION

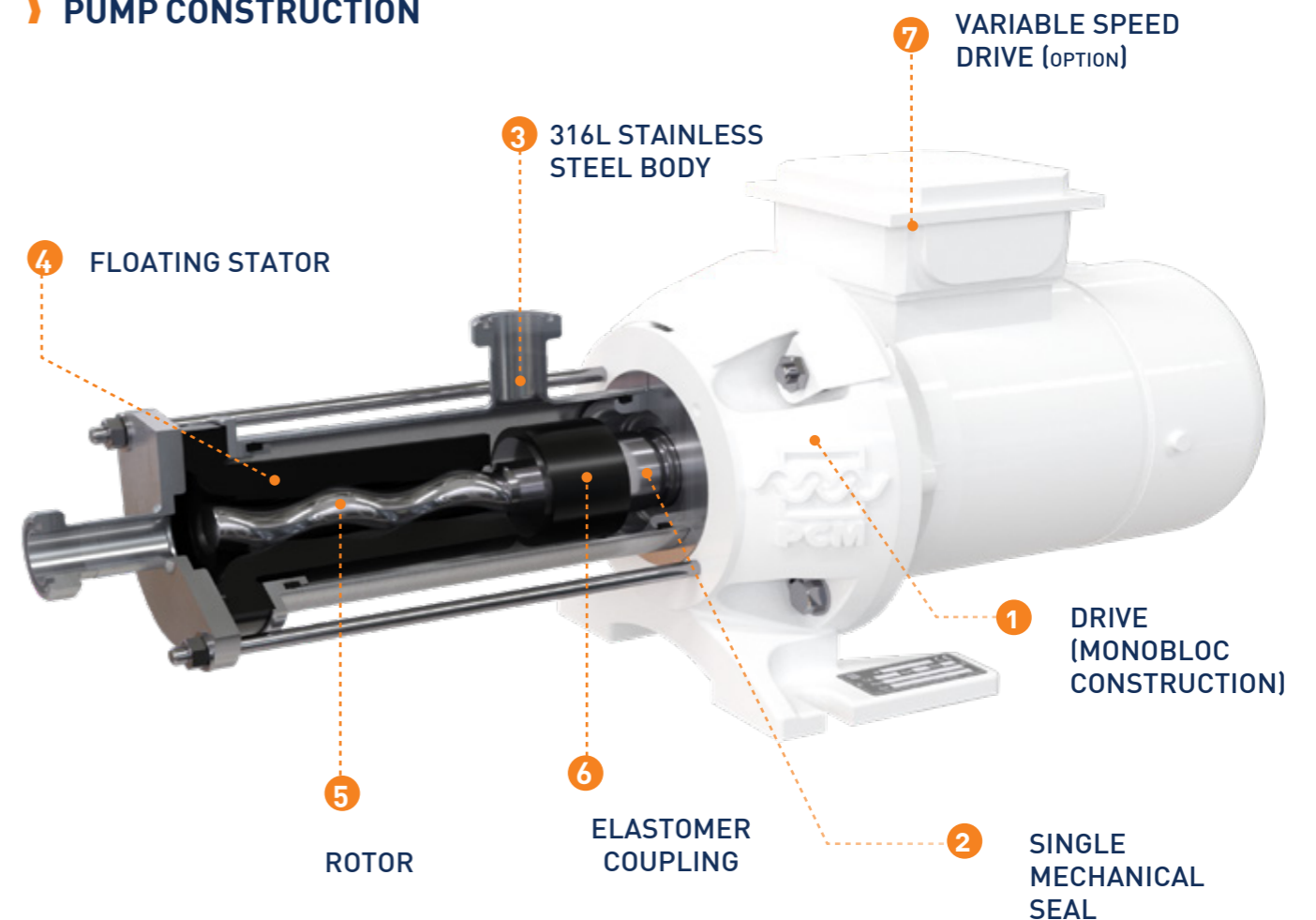

PCM ECOMOINEAU™ C WITH FLOATING STATOR BENEFITS

SPACE SAVING

- Simplified shaftline, made of 316L stainless steel, without articulation or connecting rod
- Compact elastomer coupling: in black nitrile (NBR) certified FDA and 1935/2004 food contact. This part provides the connection between the shaftline and the rotor. The coupling flexibility associated with the floating stator flexibility (without metal frame) ensures the eccentric movement of the rotor in the stator.

SIMPLIFIED MAINTENANCE

- Shorter body
- Reduced weight
- No connecting rod

VERSATILITY

- Floating stator in black nitrile (NBR) certified FDA and 1935/2004 food contact. The principle of the floating stator, without frame or metal casing, is more tolerant to dry running. For total protection, it can be equipped with a anti dry-running system which allows to control the product circulation. Simple and robust stainless steel construction.
- Can be used as a dosing pump, without pulsation
- Ideal for fragile fluids

LOW LIFE CYCLE COSTS

- Simple design
- Cost efficient maintenance
- Reduced weight



PCM IVA / LVA / GVA

Viscous and non-homogeneous products

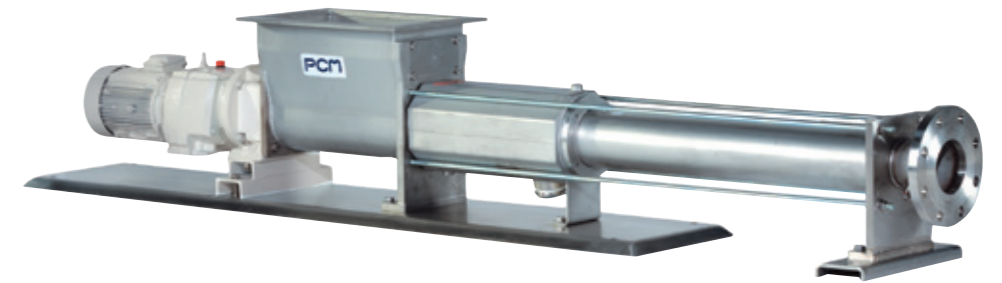

IVA / LVA / GVA pumps are fitted with a **feeder hopper** and a **conveyor screw**. The open-throat design allows the fluid to flow in without restriction while the screw feeds the materials into the rotor/stator.

These pumps are the ideal solution for the transfer of **high-viscosity, non-homogeneous and pasty products**. This is a compact solution for a **simplified integration**, a **small investment** and a **low power consumption**.



IVA model

IVA/LVA TECHNICAL PERFORMANCES

- **Pressure:** 16 bar [232 psi]
- **Flowrate:** 55 m³/h [242 USGPM]
- **Hopper:** 72x156 mm to 590x590 mm [2.80x6.14 to 23.20x23.20 inch.]

GVA TECHNICAL PERFORMANCE

- **Pressure:** 16 bar [232 psi]
- **Flowrate:** 32 m³/h [141 USGPM]
- **Hopper:** length 500-1 000-1 500 mm [19.7 - 39.4 - 59 inch.]

EXAMPLES OF APPLICATIONS

- Pectin
- Fish flesh
- Apple dregs
- Mashed potatoes
- Meat emulsions ...

› IVA/LVA PUMP CONSTRUCTION

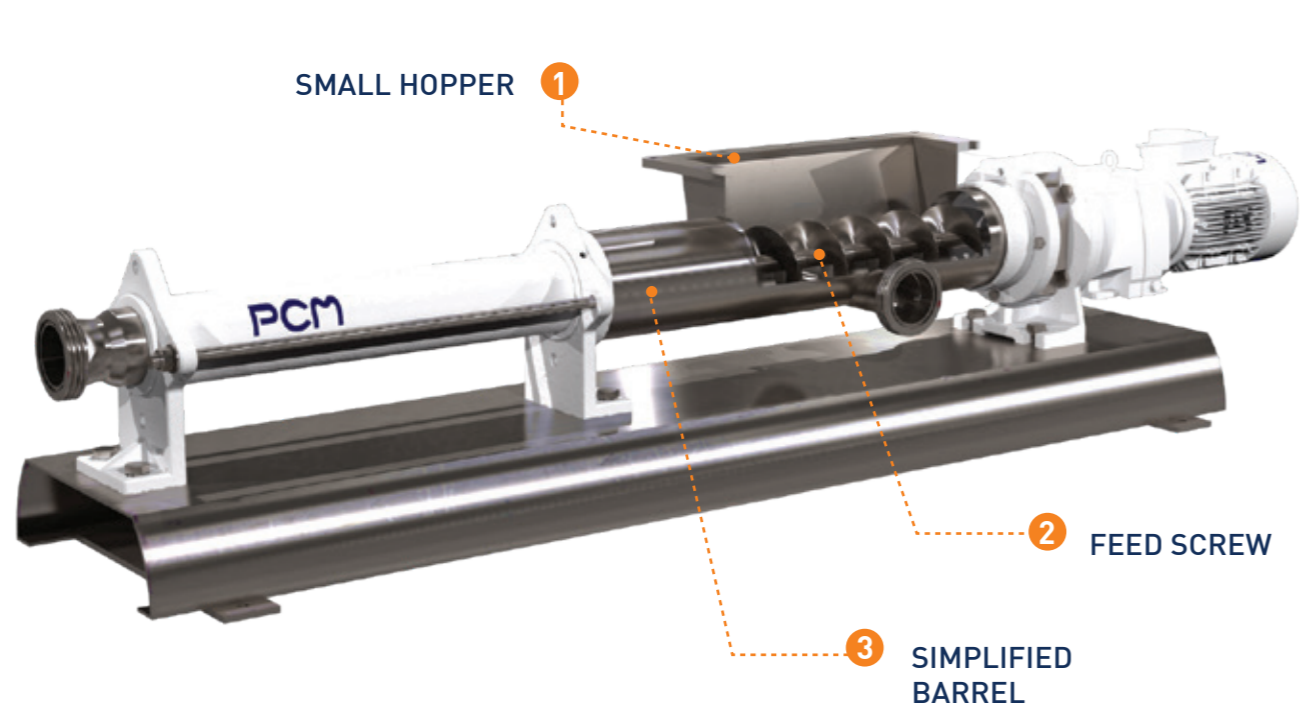

› GVA PUMP CONSTRUCTION

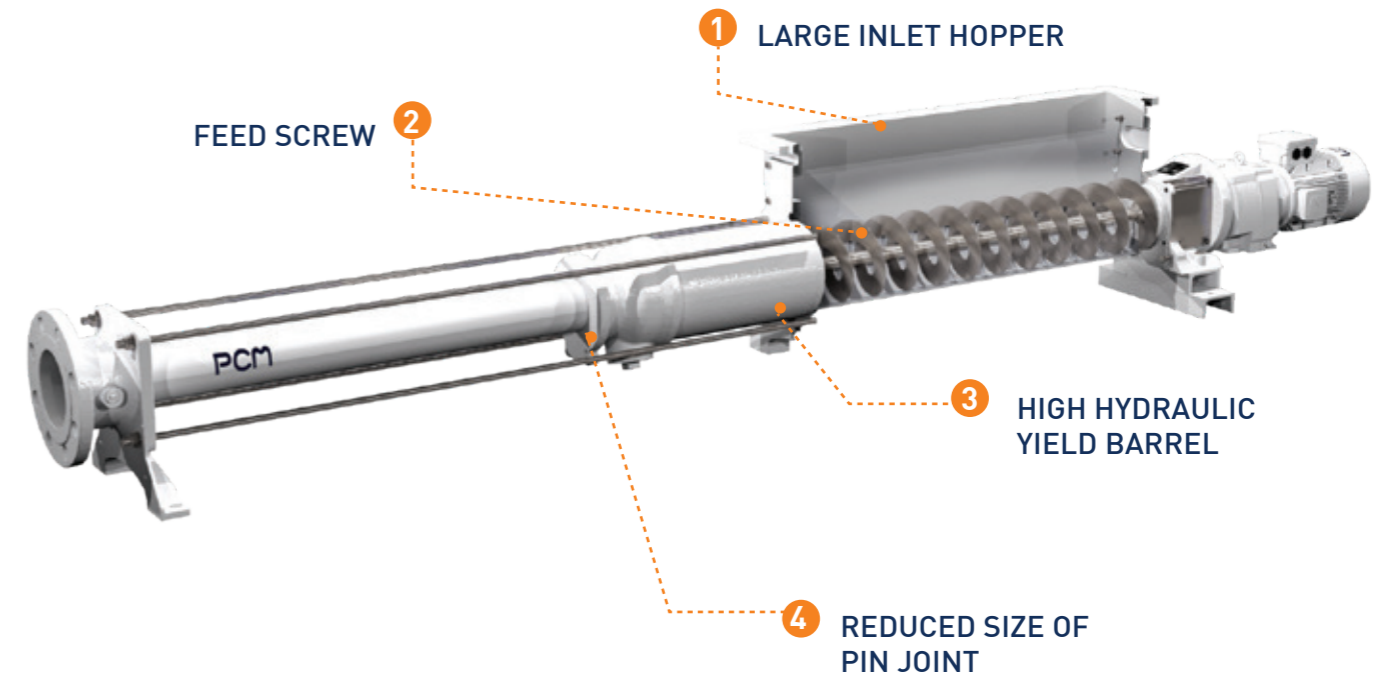

› IVA / LVA RANGE BENEFITS

COMPACT SOLUTION

- Simplified integration
- Small hopper: compact size (72x156 mm to 590x590 mm / 2.80x6.14 to 23.20x23.20 inch.)

VERSATILITY

- Transfers high-viscosity, non-homogeneous and pasty products
- The feed screw facilitates product flow
- Simplified barrel that promotes auto-flow of a more or less viscous liquid product

COST SAVING

- Small investment
- Low power consumption

› OPTIONS

- Drain plug that enables total drainage
- Polished finish (LVA option)
- Stainless steel base
- Hopper: other dimensions on demand

› GVA RANGE BENEFITS

PRODUCTIVITY

- Improved circulation of the fluid thanks to the hopper's shape
- Elimination of cavitation and elimination of the risk of product bridging in the inlet hopper
- For higher viscosity products, the GVA can be fitted with an optional motorised bridge breaker.

VERSATILITY

- Transfers very viscous products
- Accommodates non-homogeneous, pasty and sticky fluids

COMPACT SIZE

- Reduced size of pin joint that facilitates product flow

› OPTIONS

- Drain plug that enables total drainage
- Grease sealing
- Special finish: polished, glass blasted... depending on the product
- Bridge-breaker
- Flow management with level control module in the hopper
- Double jacket to maintain the product's temperature
- Built-in Cleaning In Place

DELASCO™ - DL SERIES

Peristaltic pumps for corrosive and abrasive products



With various pump constructions and a wide choice of elastomer hoses, the PCM Delasco™ range covers a **wide variety of applications** calling for heavy-duty and flexibility.

Simple to use and to maintain, PCM Delasco™ peristaltic pumps can be adapted to a multiple constraint.

Peristaltic pumps with low operating speeds are ideal for **abrasive products**: the transfer is carried out inside the hose without agitating or frothing the fluids.

They are also the perfect solution to handle **corrosive products** as only the hose is in contact with the fluid.



TECHNICAL PERFORMANCES

- **Pressure** : 15 bar [218 psi]
- **Flowrate** : 20 m³/h [88 USGPM]
- **Accessories**: hose-leak detector, pulsation dampener, vacuum pumping, trolleys

RANGE

- 6 models

EXAMPLES OF APPLICATIONS

- Viscera and offal
- Tomato puree
- Fruit puree
- Crushed vegetables
- Diatomaceous earth...

› PUMP CONSTRUCTION

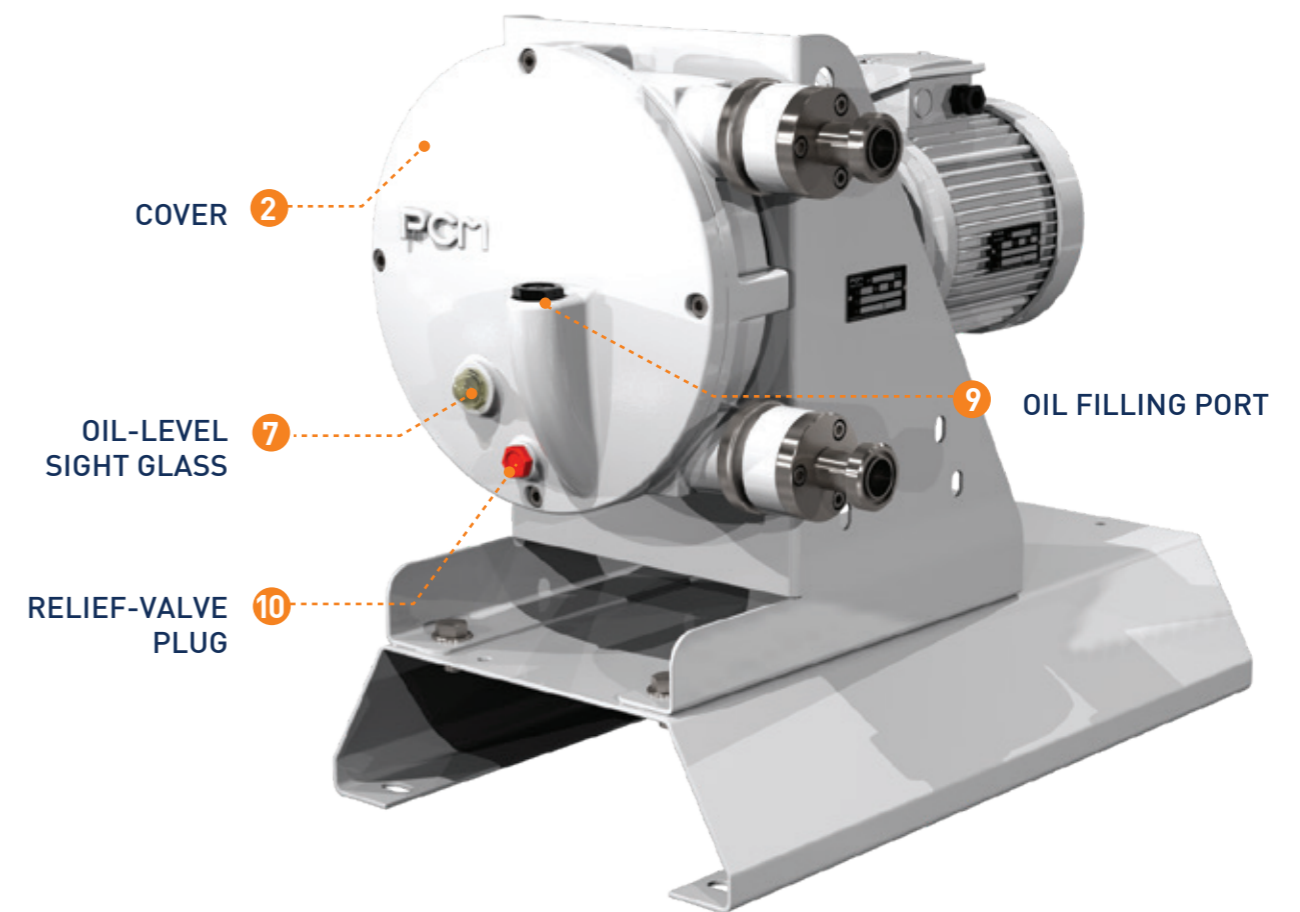
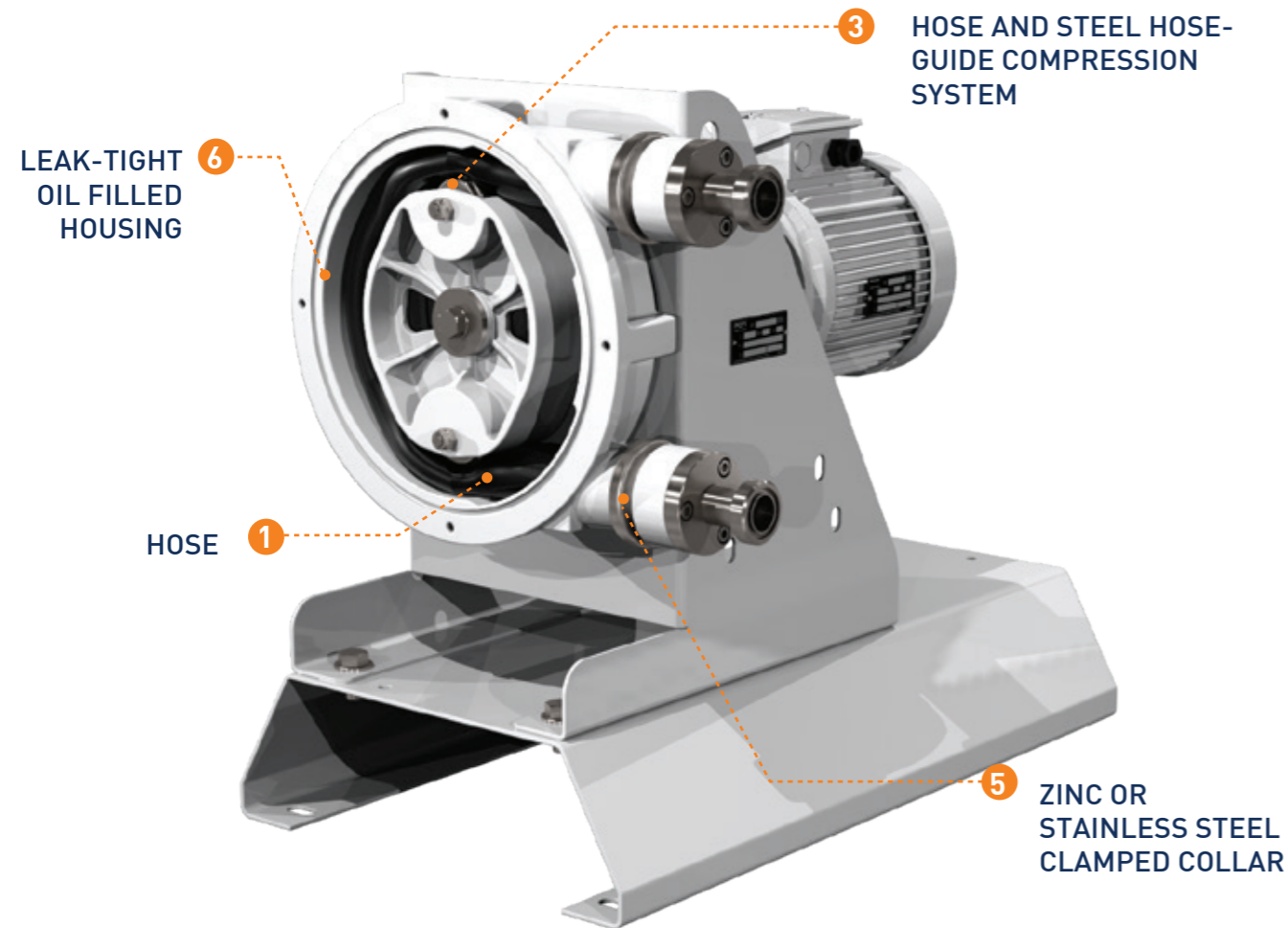

› PCM DELASCO™ RANGE BENEFITS

REDUCED MAINTENANCE

- Only one wearing part: the hose

REVERSIBILITY

- The design of the pump makes it perfectly reversible by simply acting on the direction of rotation.

VERSATILITY

- Corrosive products: only the pump hose is in contact with the fluid. This eliminates all the corrosion problems associated with acidic (hydrochloric sulfuric, nitric...) or basic (detergents sodium hydroxide or hypochlorite) products.
- Abrasive products: the elastomer hose resists better to abrasion than a metallic surface.

REDUCED LCC

- The Life Cycle Costs have been optimized at every stage of the pump life: from its conception, operational time and maintenance duties.

› WHITE FOOD NITRILE HOSES FOR DELASCO™ PUMPS

The hose is made out of white food grade nitrile. For high pressure resistance, its has 4 reinforced layers and its outside cover is made out of natural rubber for the utmost mechanical resistance.

USE:

- Max pressure: 10 bar [145 psi]
- Max temperature: 80°C [176°F]
- Cleanable in place
- Food contact oil

CERTIFICATES:

- CE 1935/2004
- FDA 21 CFR 177.2600
- DM 21/03/73

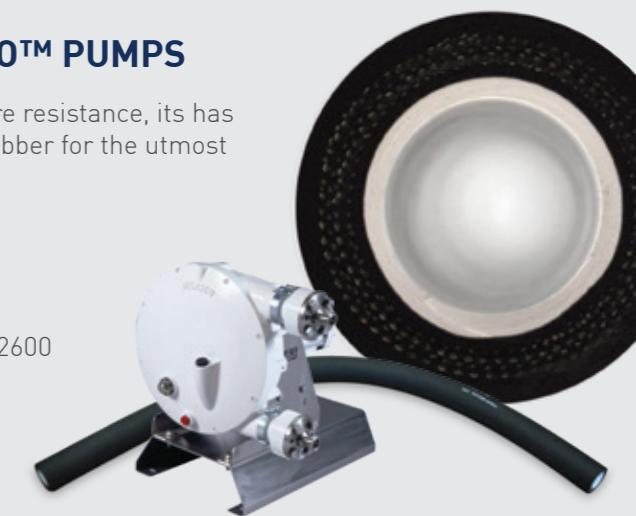

› OTHER AVAILABLE HOSES:

- **Natural rubber:** for abrasive products, diluted acids, alcohols
- **EPDM:** resistance to chemicals, concentrated acids

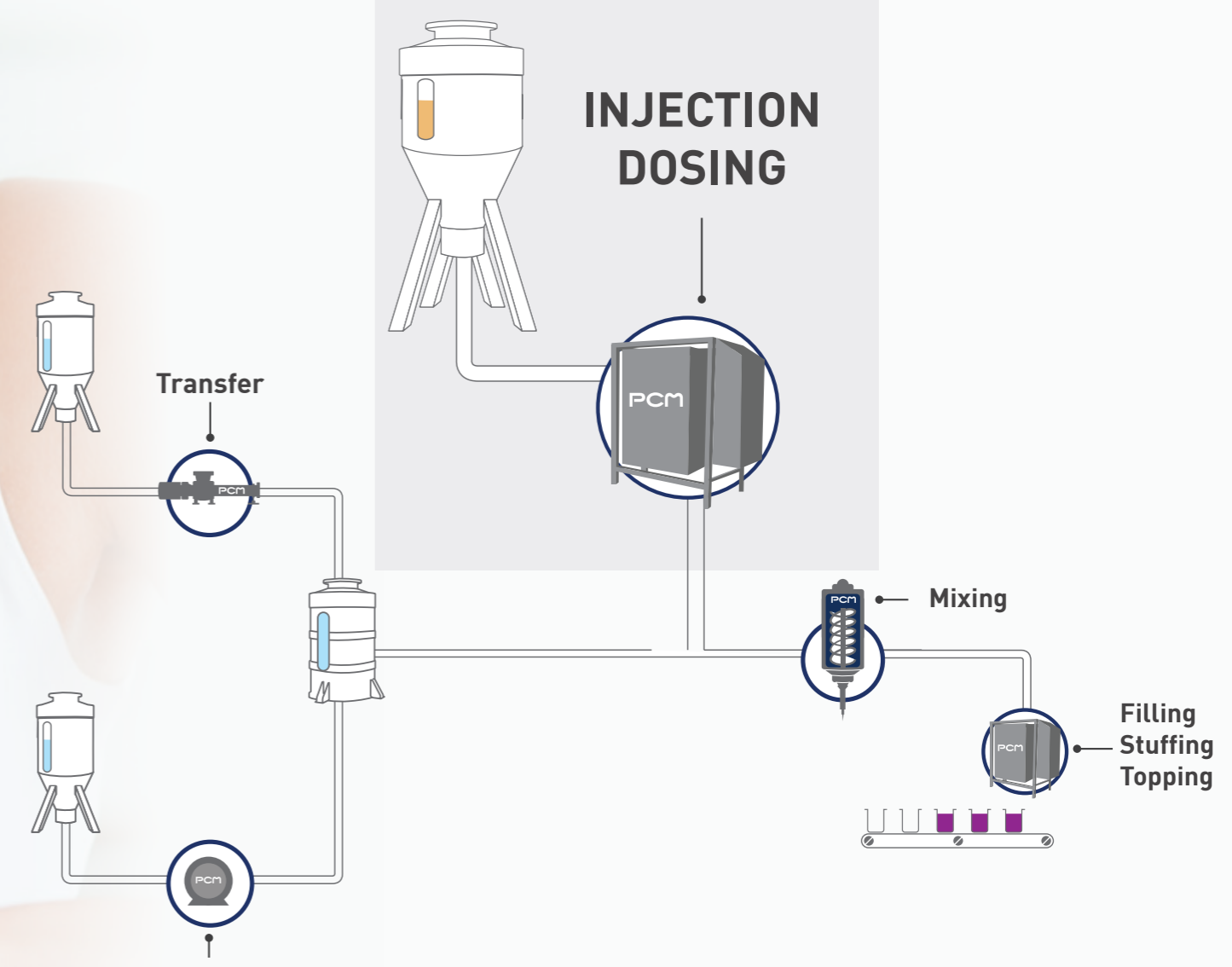

INJECTION AND DOSING

Never waste a drop: accuracy and flexibility for unrivalled productivity

PCM proposes different technologies to best meet your constraints and requirements in terms of accuracy, loss of ingredients, respect of the structure, productivity and ease of cleaning.

The Dosys™ technology is one we use most frequently for its accuracy but also to replace more expensive technologies in terms of ingredients loss. The inaccuracies and the lack of flexibility of conventional dosing systems are the primary sources of high operating costs for most food production processes.

Thus, PCM proposes inline injection solutions associated with mixing solutions allowing an optimum flexibility for an unrivalled productivity.

- PCM Dosyfruit™ Premium
- PCM Dosyfruit™ Basic
- PCM Dosing Unit
- PCM Hopper Station
- PCM Additive Station

Through each technology, PCM offers different advantages enabling us to adapt and meet your constraints.

› PCM DOSYS™ PISTON AND CONTROLLED VALVE PUMPS

These pumps enable accurate dosing, closest to the containers, of non homogeneous ingredients that may contain large pieces with minimum losses and a maximum repeatability.

› PCM MOINEAU™ PROGRESSING CAVITY PUMPS

They allow the continuous dosing of fragile ingredients for applications that may require high flowrates.

› PCM LAGOA™ DIAPHRAGM DOSING PUMPS

These diaphragm dosing pumps allow metering small doses of low viscosity/corrosive products.

VARIOUS PRINCIPLES OF INLINE INJECTION

PCM inline injection systems are particularly flexible and provide productivity gains through a fully automated process, including the detection and management of containers ending, the elimination of dilution fronts when the ingredients are changed, and the changes for cleaning processes (CIP).

Mono-flavour inline injection/mixing (before hopper)

The injection point is located before the hopper. This is a classic inline process. The dosage is proportional because the additive flowrate (ex: fruits preparation) is controlled by the main ingredient dosage (ex: white mass). A flowmeter measures the flowrate of the main ingredient and orders the Dosys™ pump to send a dose of additive (top dosing). Example of instruction: injection of one dose of additive every 3 liters.

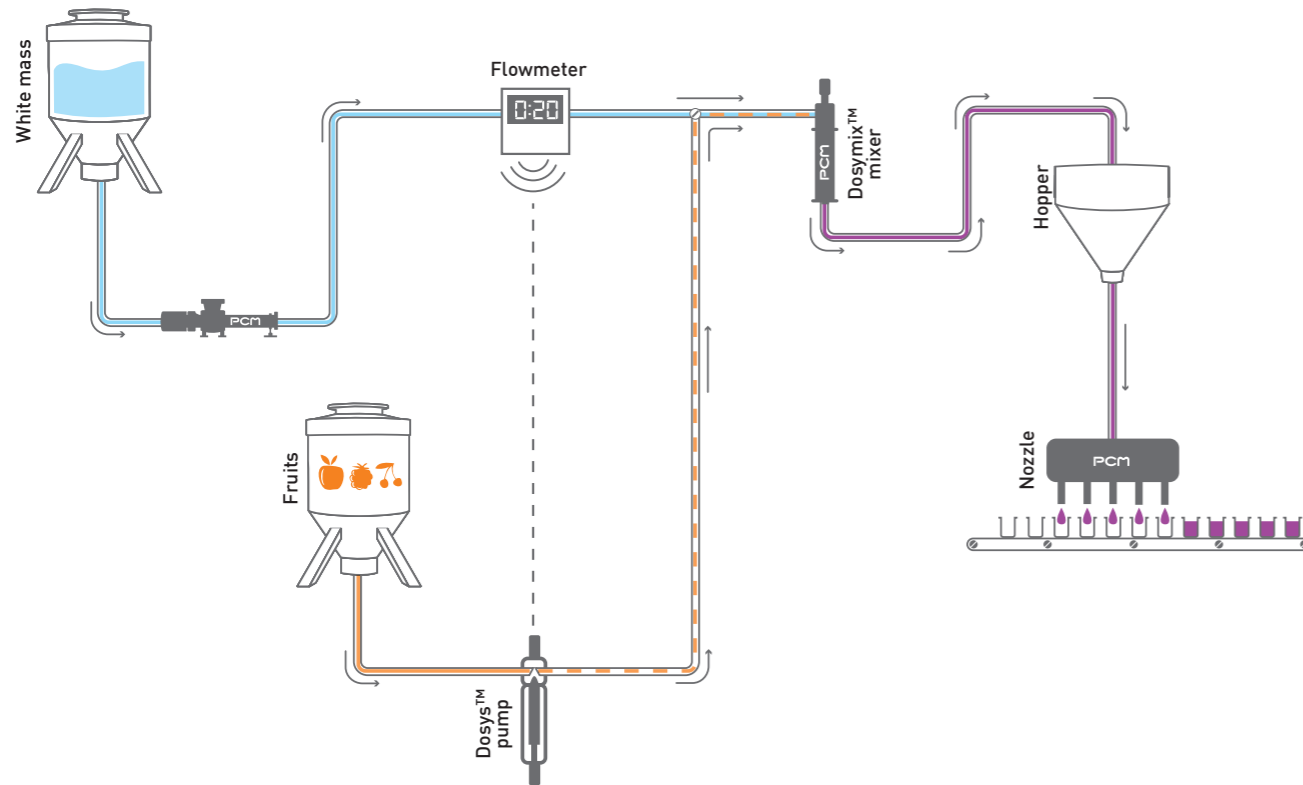

The proportion is always respected regardless the flowrate of the main ingredient.

Just in time inline injection/mixing (after hopper)

The injection point(s) are located after the hopper storing the main ingredient. This is a "just in time" process because the dosing pumps, and so the injection of additives (ex: fruits or colourings preparation), are controlled by the packaging machine.

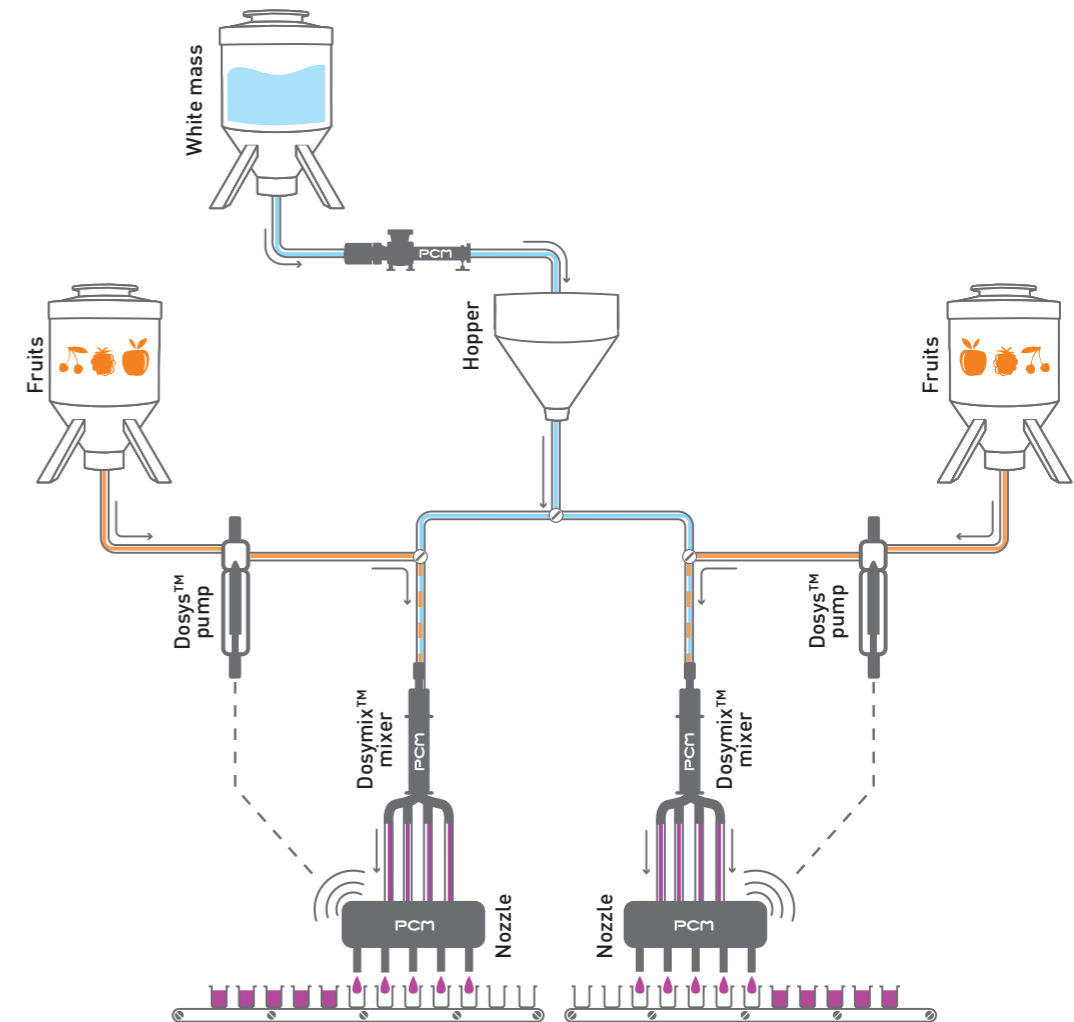

Because the mixing is done at the latest and on request just before the packaging machine, the loss of ingredients is therefore minimal.

PCM DOSYFRUIT™ PREMIUM

The reference in the industrial manufacturing process of fruit yoghurt

PCM Dosyfruit™ premium is a single or multi-ingredient dosing system with BIB or containers sucking that is fully automated. It is therefore the reference for the injection and dosing of fruit in fresh dairy products.



SYSTEM BENEFITS

INCREASE THE PRODUCTIVITY AND FLEXIBILITY OF THE INDUSTRIAL EQUIPMENT

- Reduction of machine downtimes : "all-automatic", automatic priming, automatic changeover of containers (no production shutdown), automatic CIP control
- Flexibility: management of several recipes, automatic doses adjustment (Brushless actuator)

MINIMIZE PRODUCT LOSSES

- Fruit on fruit or water on fruit push: limited product losses during recipes changeover
- Water push before cleaning: product recovering on pipes at the end of production
- Dosing synchronization by the packaging machine (just in time)
- Dosys™ pump accuracy: avoids overdosing

100% RELIABLE AND REPEATABLE

- Dosys™ technology (see page 7)

GENTLE HANDLING OF SENSITIVE INGREDIENTS WITH OR WITHOUT MARKERS

HYGIENIC

- Hygienic design of components
- Complete automatic cleaning and sterilization in place (sterile air, steam, air and steam filtration, containers foot sterilization)

SYSTEM CONSTRUCTION

- Dosys™ technology
- Actuator with Brushless drive
- Controlled automatic valves
- End of containers and degassing detection pot
- Sight glass on suction pipe
- Integration of utilities (sterile air, water, CIP, steam)
- Container overpressure hoses
- Drainage collection bin
- Integrated control cabinet with control panel (IHM)
- All stainless steel construction

Options

- Injection point

COMPACT VERSION

Containers integration into the skid

Options

- Containers weighting



PCM DOSYFRUIT™ BASIC

An economical solution for a semi-automatic process for the production of fruit yoghurt

PCM Dosyfruit™ basic is a single ingredient injection system with BIB or containers sucking. This economical solutions is perfectly suited to installations of fresh dairy products industries.

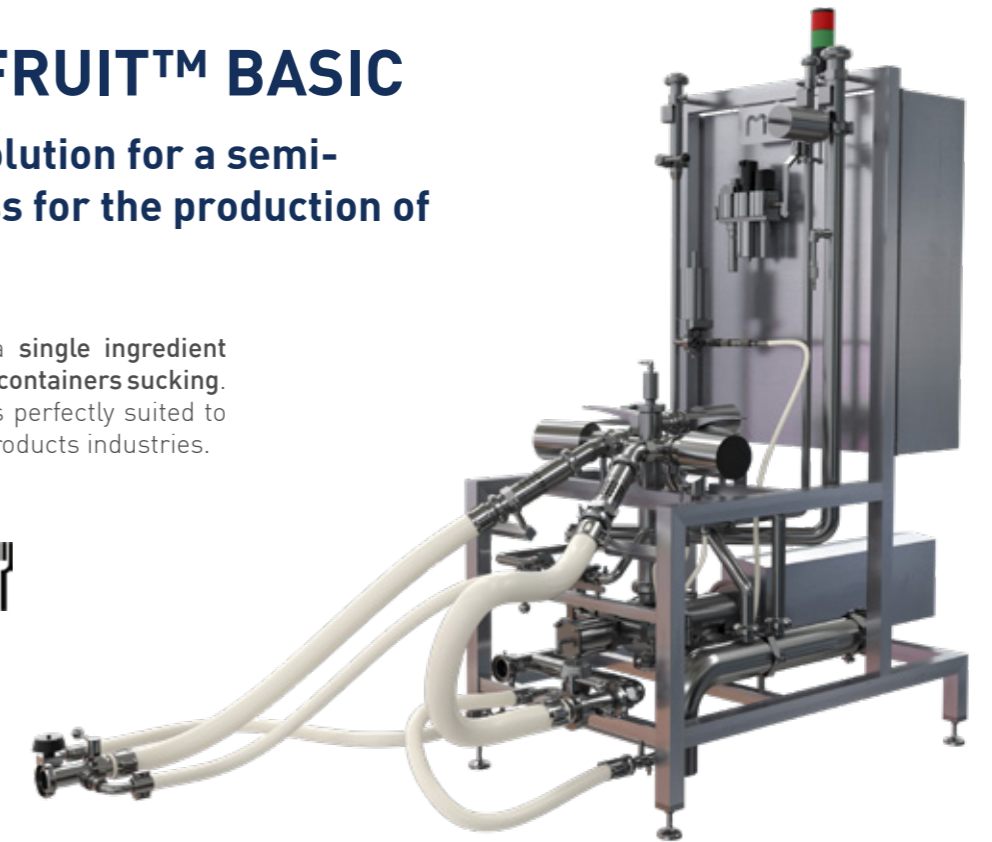

SYSTEM BENEFITS

SIMPLICITY OF USE AND FLEXIBILITY

- Manual sleeve priming
- Automatic containers changeover (option)
- Automatic CIP control
- Several recipes management
- Manual dose adjustment (pneumatic actuator)

MINIMIZE PRODUCT LOSSES

- Fruit on fruit or water on fruit push: limited product losses during recipes changeover
- Water push before cleaning: product recovering on pipes at the end of production
- Dosing synchronization by the packaging machine (just in time)
- Dosys™ pump accuracy: avoids overdosing

100% RELIABLE AND REPEATABLE

- Dosys™ technology (see page 7)

GENTLE HANDLING OF SENSITIVE INGREDIENTS WITH OR WITHOUT MARKERS

HYGIENIC

- Hygienic design of components
- Manual cleaning in place and sterilization of sleeves

SYSTEM CONSTRUCTION

- Dosys™ technology
- Pneumatic actuator
- Manual and/or automatic valves
- End of containers and degassing detection pot
- Sight glass on suction pipe
- Integration of utilities (water, CIP, steam)
- Integrated control cabinet with control panel (IHM)
- All stainless steel construction

Options

- Injection point

PCM HOPPER STATION

A cleanable in place solution with loading hopper for semi-industrial or artisanal applications

With a bulk racking (hopper), the PCM Hopper Station single or multi-ingredient dosing system is the ideal equipment for small production units. This hopper dosing station is perfect for an accurate dosing of heterogeneous fluids.



SYSTEM BENEFITS

MODULAR AND AUTONOMOUS SYSTEM

- Number of hoppers and sizes to choose from (80L or 200L / 21.13 or 52.83 usgal)
- Autonomous : possibility of integrating a CIP back pump

AUTOMATIC CIP

- The overall system is cleanable in place automatically, including the hopper (without disassembly)

100% RELIABLE & REPEATABLE

- Dosys™ technology (see page 7)

RESPECT OF INGREDIENTS WITH OR WITHOUT MARKERS

HYGIENIC

- Hygienic design of components
- The overall system is cleanable in place automatically

SYSTEM CONSTRUCTION

- Dosys™ technology
- Pneumatic or Brushless actuator
- 80L [21.13 usgpm] standard hopper
- Detection of cover closure
- Detection of product level in the hopper
- Manual and/or automatic valves
- Integration of utilities (water, CIP)
- Cleaning ball integrated into the hopper
- Bridging table for switching from production mode to CIP mode

- Integrated control cabinet with control panel (IHM)
- All stainless steel construction

Options

- Moineau™ technology
- 200L [52.83 usgpm] hopper
- Duo or trio version for multi-ingredient applications

PCM DOSING UNIT

A versatile and cost-effective solution for small production batches

The PCM Dosing Unit dosing skid has been specially designed for single or multi-ingredient heterogeneous dosing (liquid or solid) with BIB, container or bulk racking (hopper). It is ideal for the production of small batches, especially for convenience food, bakery or dairy products markets.



SYSTEM BENEFITS

VERSATILITY

- Adaptable to different sucking types
- Applications versatility: convenience food, sauces, fruits...

COMPACTNESS & MOBILITY

- Low footprint: ideal for small production units, easy integration in existing units

100% RELIABLE & REPEATABLE

- Dosys™ technology (see page 7)

RESPECT OF INGREDIENTS WITH OR WITHOUT MARKERS

HYGIENIC

- Hygienic design of components
- Cleaning in place of dosing units

SYSTEM CONSTRUCTION

- Dosys™ technology
- Pneumatic or Brushless actuator

- Integrated control cabinet with control panel (only for Brushless version)
- All stainless steel construction
- Baseframe on feet or wheels

Options

- Moineau™ technology
- Removable 50L [13.2 usgpm] loading hopper
- Detection of product level in the hopper
- Duo or trio version for multi-ingredient applications

PCM ADDITIVE STATION

The compact solution for injecting small liquid doses

The PCM Additive Station is a pumping equipment of single or multi-flavours or liquid additives with drum suction lance. The flavour or additive dose is injected upstream from mixing step into the transfer piping of the main product.



SYSTEM BENEFITS

COMPACT & FLEXIBLE SKID

- Compact: containers based on the frame
- Flexibility: several recipes management, doses adjustment (from 0.05 to 40 ml / 0.010 USGPM)

EASE OF USE

- Quick product priming: suction pipe as close as possible to the dosing unit and immersed directly into the container
- Synchronization of the dosage through the conditioning machine (just-in-time) or according to the flowrate of the main product
- At the end of production, the suction pipe can be positioned in its cleaning sleeve

100% RELIABLE & REPEATABLE

- Dosys™ technology (see page 7)
- Perfect accuracy of the required doses (repeatability: 0,5 %)

HYGIENIC

- Hygienic design of the components
- Cleaning of place of dosing units and suction pipes

SYSTEM CONSTRUCTION

- Dosys™ technology
- Pneumatic or Brushless actuator
- Vertical pump configuration
- Suction pipe adapted to the container
- Suction wand CIP sleeve

- Integrated control cabinet with control panel (IHM)
- All stainless steel construction

Options

- End of drum detection device
- Injection point
- Containers weighting
- Doses detection

PCM LAGOA

The simple and reliable diaphragm dosing pump

The Lagoa pump is designed for dosing liquid additives, disinfectant products (acid, soda, detergent...) for cleaning in place applications.



PUMP BENEFITS

SIMPLE AND ROBUST CONSTRUCTION

- The pump is driven by a direct mounted light alloy motor with IP55 protection.
- The casing is made of cast aluminium alloy.
- The bearings are greased for life, making the motors maintenance-free.
- The pumphead is easy to remove and change.

RELIABILITY

- Reliability of metering.(accuracy +/-1%)
- The stroke adjustment mechanism can be locked in position to ensure that stroke length remains at its set point.

VERSATILITY

- Pumpheads are available in many material combinations. It consists of 1 suction check valve, 1 discharge check valve, 1 liquid end body.
- Dry-running.

PUMP PERFORMANCES

- Maximum flowrate: 315 l/h per pumphead [1.38 gpm]
- Maximum pressure: 12 bars [174 psi]
- Maximum temperature: 90°C [194°F]
- Adjustable from 10 to 100%

PUMP CONSTRUCTION

- Diaphragm pump technology
- Electro-mechanical drive
- Light alloy motor with IP55 protection
- Cast aluminium alloy casing
- Standard configuration: 1 suction check valve, 1 discharge check valve, 1 liquid end body
- The capacity is set by turning the micrometer dial which is fitted with vernier scale graduated in percentage stroke length. Electric servo control can be fitted.

Options & accessories

- Adjustment controlled by an electric servo-motor (in option)
- Foot valves
- Injection rod
- Safety and retention valves
- Pulsation dampers

LAGOA MULTIPLEXING BENEFITS

- Proportional metering with different fluids
- Greater flow rate
- Pump stroke phases, linear flow



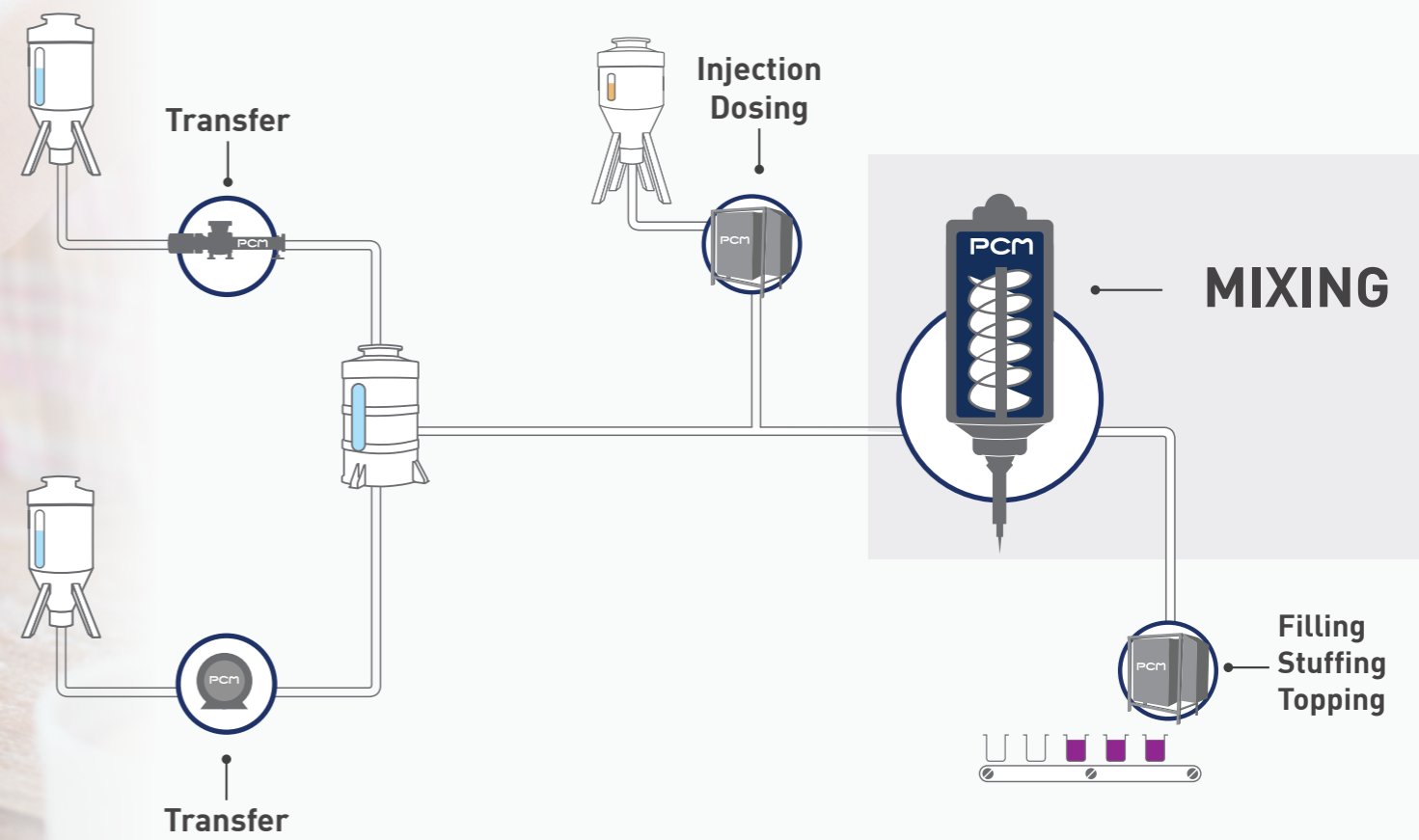

MIXING

Mix with care: introducing a better way to mix with optimized costs!

PCM gives the opportunity to customers to optimise the overall operating cost through an inline process rather than expensive and space consuming batch solutions.

The principle of inline mixing consists in replacing the batch ingredient mixing tank with a continuous mixer. The mixing operation is thus carried out more quickly, in a single pass, and guarantees a proportional and homogeneous mixing thanks to an increased dispersion power. It allows the manufacture of small batches with quick changeovers for various recipes (see page 42-43 - injection and inline mixing principles).

- PCM Dosymix™
- PCM Dostam

› PCM DOSYMIX™ DYNAMIC MIXER

A dynamic mixer will be the ideal choice for mixing heterogeneous or homogeneous, viscous, shear sensitive products with or without pieces.

The rotation of the screw allows easy and efficient cleaning in place.

› PCM DOSTAM STATIC MIXER

A static mixer will be recommended for mixing homogeneous liquids without solids.

Our systems guarantee homogeneous mixing without altering the ingredients or the product texture. This eliminates use of costly additives to recover the texture at the end of operation line.

DOSYMIX™ INLINE MIXER

Provider of dynamic mixing

The Dosymix™ dynamic mixer preserves the most important asset in your production line: the ingredients.

Thanks to the body design, with twin helices in opposite directions welded to an impeller, an upward and downward flow is created for **gentle mixing of ingredients and accurate distribution of mixed product.**

The Dosymix™ is **3A** certified (American standards) to ensure a better cleaning efficiency during **Cleaning In Place and/or Sterilisation In Place.**



TECHNICAL PERFORMANCES

- Pressure : 10 bar [145 psi]
- Flowrate : 6 m³/h [26 usgpm]
- Particles size* : 25 mm [1 inch]

RANGE

- 5 models

* According to your products, the Dosymix™ can mix bigger particles.

EXAMPLES OF APPLICATIONS

- Fruits, pulp, syrup in stirred yoghurt
- Sugar, glucose, vitamins, flavours in cream and cheese
- Preparations including grapes in desserts
- Ferment, rennet in cheese...

MIXER CONSTRUCTION

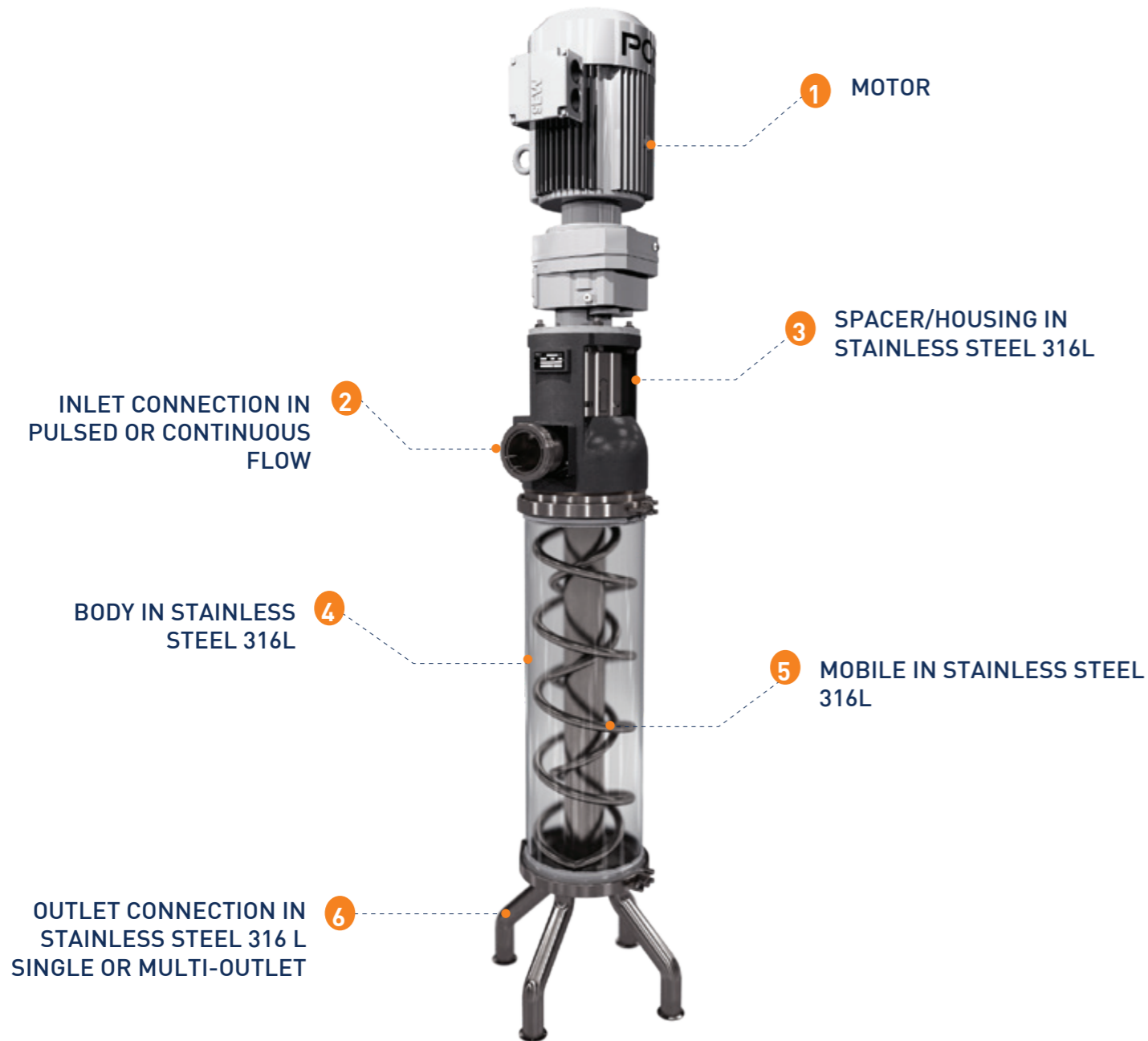

OPERATING PRINCIPLE

The residence time in the mixer body (measured in seconds) ensures the quality of the mix. The residence time depends on 2 factors: the internal volume of Dosymix™ and the production rate (l/h).

OPTIONS

- Tandem mechanical seal
- Heating jacket: for particular applications requiring specific temperature
- Drive cover

PCM DOSYMIX™ RANGE BENEFITS

IDEAL FOR SHEAR SENSITIVE PRODUCTS containing solids or fibers

- The round shaped helix prevents the adhesion of ingredients
- Designed for products mixing with different viscosities and/or proportions

3A HYGIENIC CONSTRUCTION

- CIP and SIP facilitated

LOW INTERNAL VOLUME to minimize product losses

MULTI OUTLET

- Precise distribution and possibility to delay product finalisation

EASY AND QUICK ASSEMBLY/DISASSEMBLY

- Body fixed by Tri-Clamp connection
- Mechanical seal provided in cartridge

MECHANICAL SEAL standardised with HyCare™ progressing cavity pump

PCM DOSYMIX™ TECHNICAL PERFORMANCES

Models	Internal capacity L [USGAL]	Weight kg [lbs]	Drive power (kW)	Speed rotation - Fixe (rpm)	Speed rotation - Variable (rpm)	Connections
DM 1000	3.8 [1]	47 [103.6]	0.75	145 or 300	60 to 300	SMS DIN 11851 DIN 11864 Tri clamp Smooth end
DM 2000	8 [2.1]	53 [116.8]	0.75			
DM 4000	17 [4.5]	90 [198.4]	2.2			
DM 8000	23 [6.1]	107 [235.9]	4			
DM 10 000	30 [7.9]	110 [242.5]	4			

Models	Ø inlet mm [inch]	Outlet manifold - Number of outlet & Ø mm [inch]				
		1	2 to 4	5 & 6	7 & 8	9 to 12
DM 1000	51 [2]	51 [2]	25/38 [1/1.5]	25 [1]	25 [1]	-
DM 2000	51 [2]	51 [2]	25/38 [1/1.5]	25 [1]	25 [1]	-
DM 4000	63.5 [2.5]	63 [2.48]	25/38 [1/1.5]	25/38 [1/1.5]	25 [1]	25 [1]
DM 8000	76 [2.99]	76 [2.99]	25/38/51 [1/1.5/2]	25/38/51 [1/1.5/2]	25/38 [1/1.5]	25/38 [1/1.5]
DM 10 000	76 [2.99]	76 [2.99]	25/38/51 [1/1.5/2]	25/38/51 [1/1.5/2]	25/38 [1/1.5]	25/38 [1/1.5]

PCM DOSY MIX™ WITH BUFFER HOPPER

Two main functions for a minimal environment

By combining all the functions of a buffer hopper with the PCM Dosymix™ mixer, PCM guarantees a uniform inline mixing that respects your recipes.

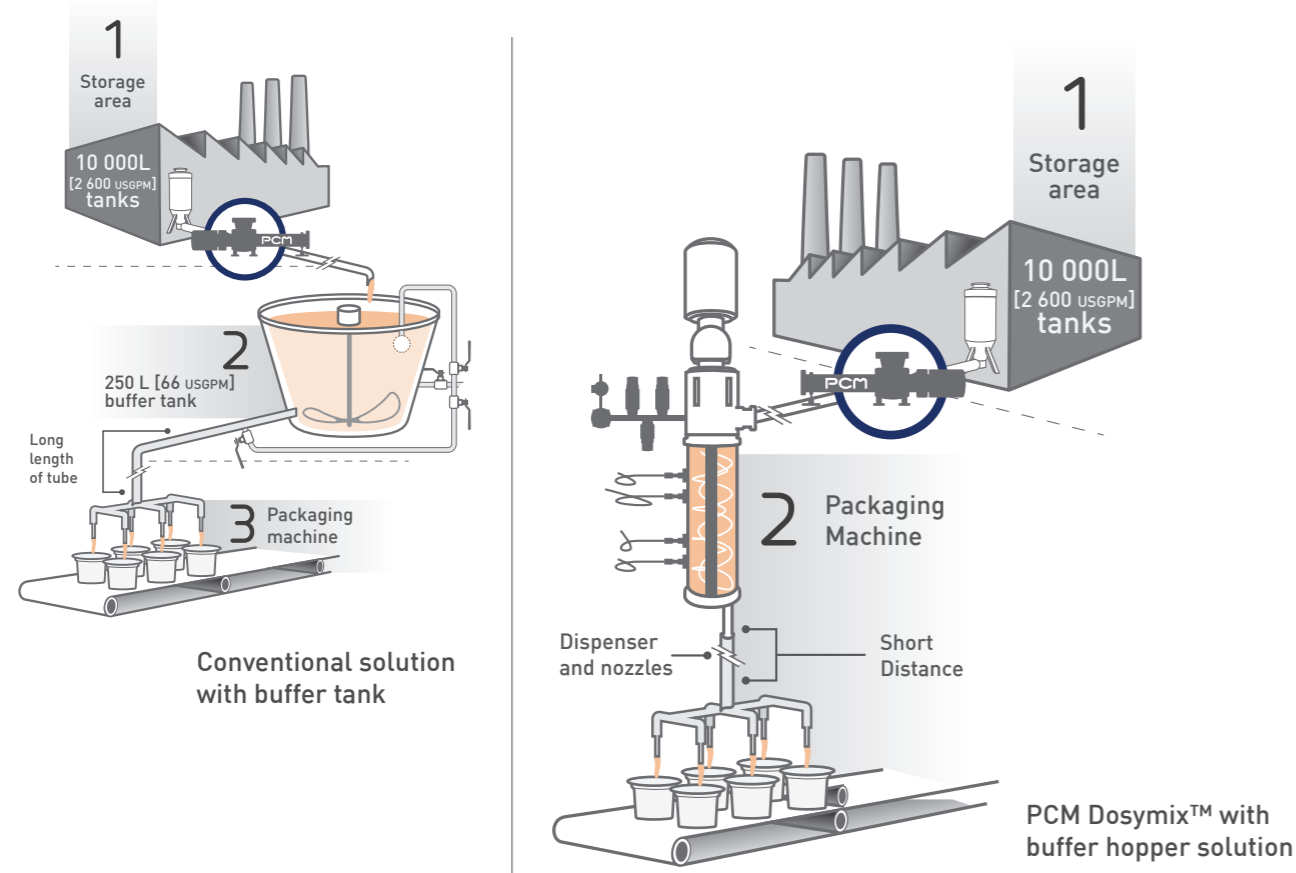

PCM DOSY MIX™ WITH BUFFER HOPPER BENEFITS

TWO FUNCTIONS IN ONE

- Function #1 : Buffer hopper with low capacity, positioned before the packaging dosing unit, offering the benefits of a "just in time" production
- Function #2 : Inline dynamic mixer ensuring an homogenization or suspension of the markers (avoiding the decantation of the product before the final dosing).

REDUCED ACQUISITION COSTS compared to a batch mixing solution

- Removal of a buffer tank and valve sets from the CIP process

LIMITED PRODUCT LOSSES

- The buffer hopper mixer is integrated as close as possible to the packaging dosing units
- The level management inside the mixer body makes the recipes changeovers more flexible

HYGIENIC DESIGN

AIR REGULATION

- allowing the constant management of the pressure inside the mixer body (pressurization during the dosing and degasing, if necessary during overpressure)

INTEGRATION ON NEW OR EXISTING MACHINE

EASY CLEANING AND SIMILAR TO A PROCESS PIPING SYSTEM

- No tank with large volume to clean, avoids valve sets and bypasses during CIP/sanitation phases

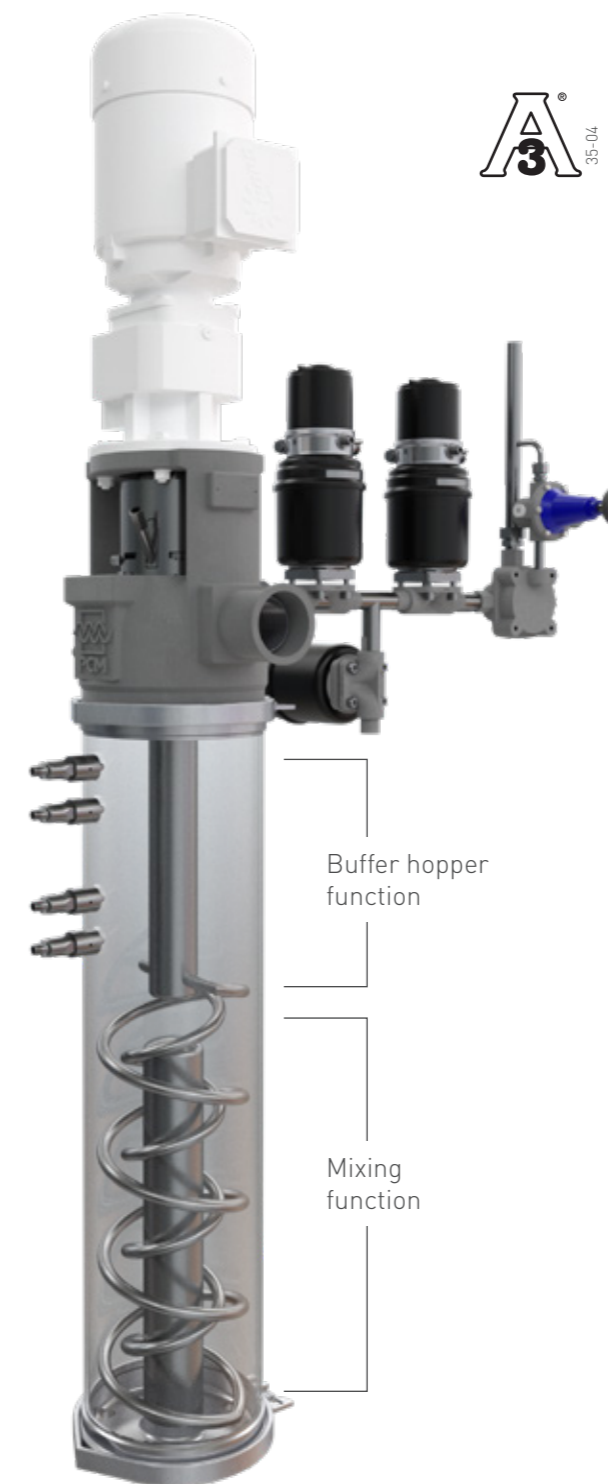

CONSTRUCTION

- PCM Dosymix™ dynamic mixer
- Internal capacity of the mixer body: from 8L to 30L [2.11 to 7.9 usgal]
- Mixing capacity: from 3.5L to 17L [0.8 to 4.5 USGAL]
- Sensors for level management (low/high level regulation, safety and end of production alarms)
- An air regulator equipped with a pressure gauge
- Three diaphragm valves for the production and CIP management
- Single or multi-outlets, smooth ends in option
- Clamp collars to ease maintenance and accessibility

Options

- Frequency converter (in option)

APPLICATIONS

- Just in time mixing: fruits in stirred yoghurts...
- Maintaining the markers in suspension: vegetables with sauces, vinaigrette with or without herbs...

DOSTAM INLINE MIXER

The static mixer accessible to everyone

With a simple design, the Dostam is a static mixer easy to integrate in your installation.

No power is required to use it. Product is pumped through the static mixer via the transfer pump located upstream of the installation.

PCM Dostam is recommended for the mixing of homogeneous fluids without pieces.



TECHNICAL PERFORMANCES

- Flowrate : 0.8 to 60 m³/h [3.52 to 264 USGPM]

RANGE

- 6 models

EXAMPLES OF APPLICATIONS

- Oil and flavours, vitamins
- Drinking yoghurts, aromas, pulps
- Beverages, water, syrup
- Chocolate, flavours

MIXER CONSTRUCTION

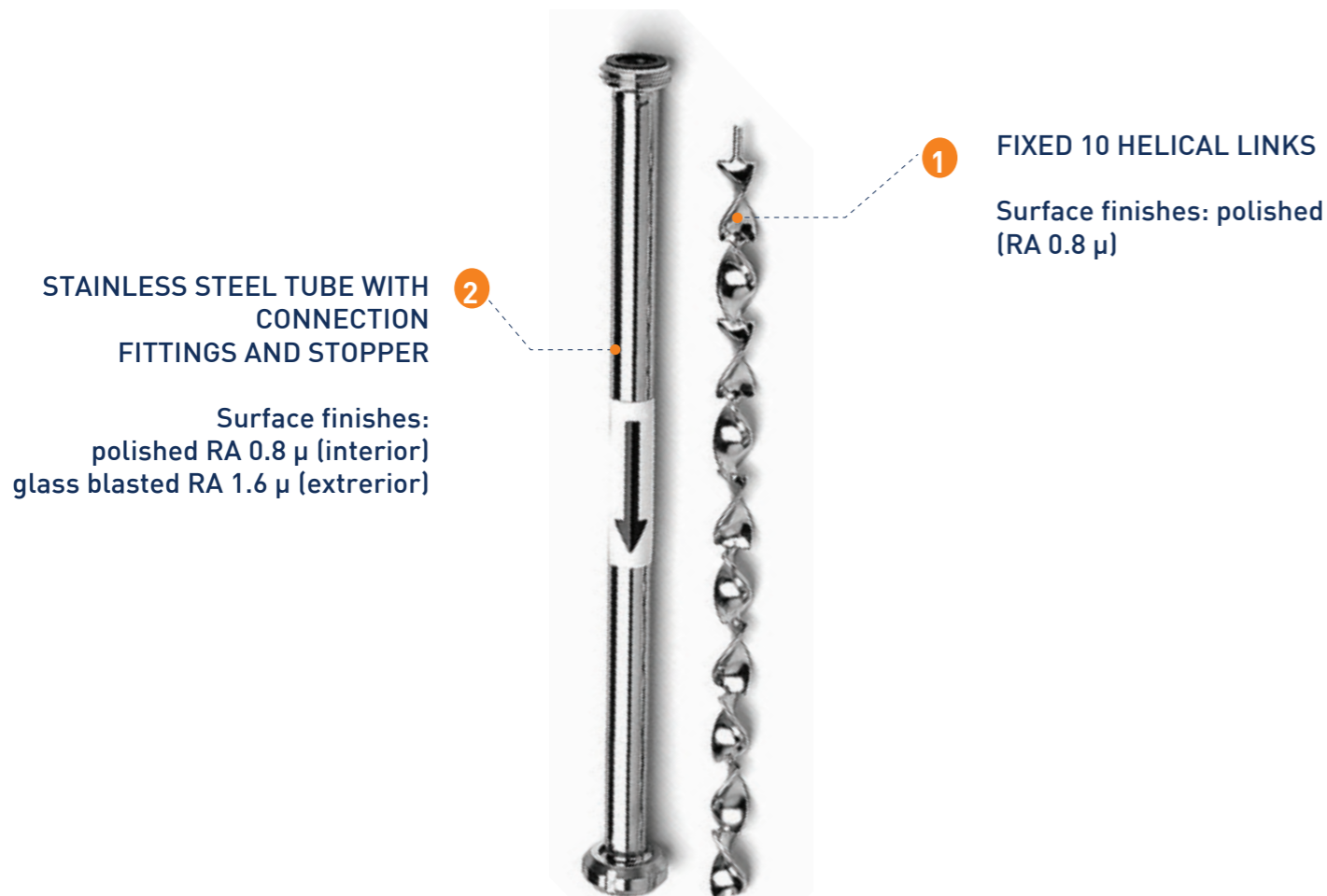

OPERATING PRINCIPLE

The fluid velocity through the chain enables efficient mixing.

When the fluid encounters the 1st link, it is divided into two streams, and then four in the 2nd link, and so forth. This division of the flow as well as the fluid rotation through the crosscutting 90° left and 90° right of the links, allows homogeneous mixing.

The upstream pumps, for bases and additives, can be set up with a continuous flowrate (Moineau™ technology) or with a synchronised pulsating flow (Dosys™ technology).

The mixer must be correctly sized to provide sufficient operating speed and guarantee a mixture quality.

DOSTAM RANGE BENEFITS

DESIGNED FOR NON HOMOGENEOUS PRODUCTS MIXING

The Dostam range consists of 5 models enabling to handle from 800 liters to 30 000 liters/h [211.33 to 7 925.16 USGPH]. It is the **ideal solution for mixing homogeneous or non sensitive fluids** such as: water, syrup, drinking yoghurts, fruits pulps, oils, flavours.

LOW INTERNAL VOLUME

to minimize product losses. The low internal volume of these mixers is comprised between 0.2 liters to 12 liters [0.05 to 3.30 USGPM] depending on the model. It is extremely low and advantageous during installation cleaning.

EASY INTEGRATION

Although links ramp is a complex and technical component, the Dostam is a simple equipment to integrate into your industrial process as it can be simply connected to the existing piping.

CONSTRUCTION

Vertical or horizontal downward

ENERGY SAVINGS AND EASY MAINTENANCE

PCM Dostam is a static mixer. There is no drive, the fluid transfer is generated through the upstream pump. **Our mixers contain no moving parts, that means no wearing parts** (excluding joints).

DOSTAM TECHNICAL PERFORMANCES

Models	Internal capacity L [USGAL]	Ø inlet exterior pipe mm [inch]	Ø inlet interior pipe mm [inch]	Total length mm [inch]					Ø SMS & Tri Clamp mm [inch]	Ø DIN male mm [inch]
				Smooth end	SMS	DIN 11851	DIN 11864-1 Form A	CLAMP		
EDSA-02510	0.18 [0.05]	25 [1]	22.6 [1]	450 [17.72]	484.5 [19.07]	501 [19.72]	533 [20.98]	497 [19.57]	25 [1]	25 [1]
EDSA-03810	0.67 [0.18]	38 [1.5]	35.6 [1.42]	698 [27.58]	737 [29.02]	757.2 [29.81]	793 [31.22]	745 [29.33]	38 [1.5]	40 [1.57]
EDSA-05110	1.67 [0.44]	51 [2]	48.6 [1.90]	906 [35.67]	946 [37.24]	969 [38.15]	1 002 [39.45]	953 [37.52]	51 [2]	50 [1.97]
EDSA-06310	3.13 [0.83]	63.5 [2.5]	60.3 [2.38]	1 089 [42.87]	1 133 [44.61]	1 161 [45.71]	1 210 [47.64]	1 136 [44.72]	63 [2.5]	65 [2.5]
EDSA-07610	5.33 [1.41]	76 [3]	72.8 [2.87]	1 274 [50.16]	1 320 [51.97]	1 356 [53.38]	1 399 [55.08]	1 321 [52.01]	76 [3]	80 [3.15]
EDSA-10410	12.57 [3.30]	104 [4.1]	100 [3.9]	1 601 [63.03]	1 650 [64.96]	1 699 [66.89]	1 731 [68.15]	1 644 [64.72]	104 [4.1]	100 [3.9]

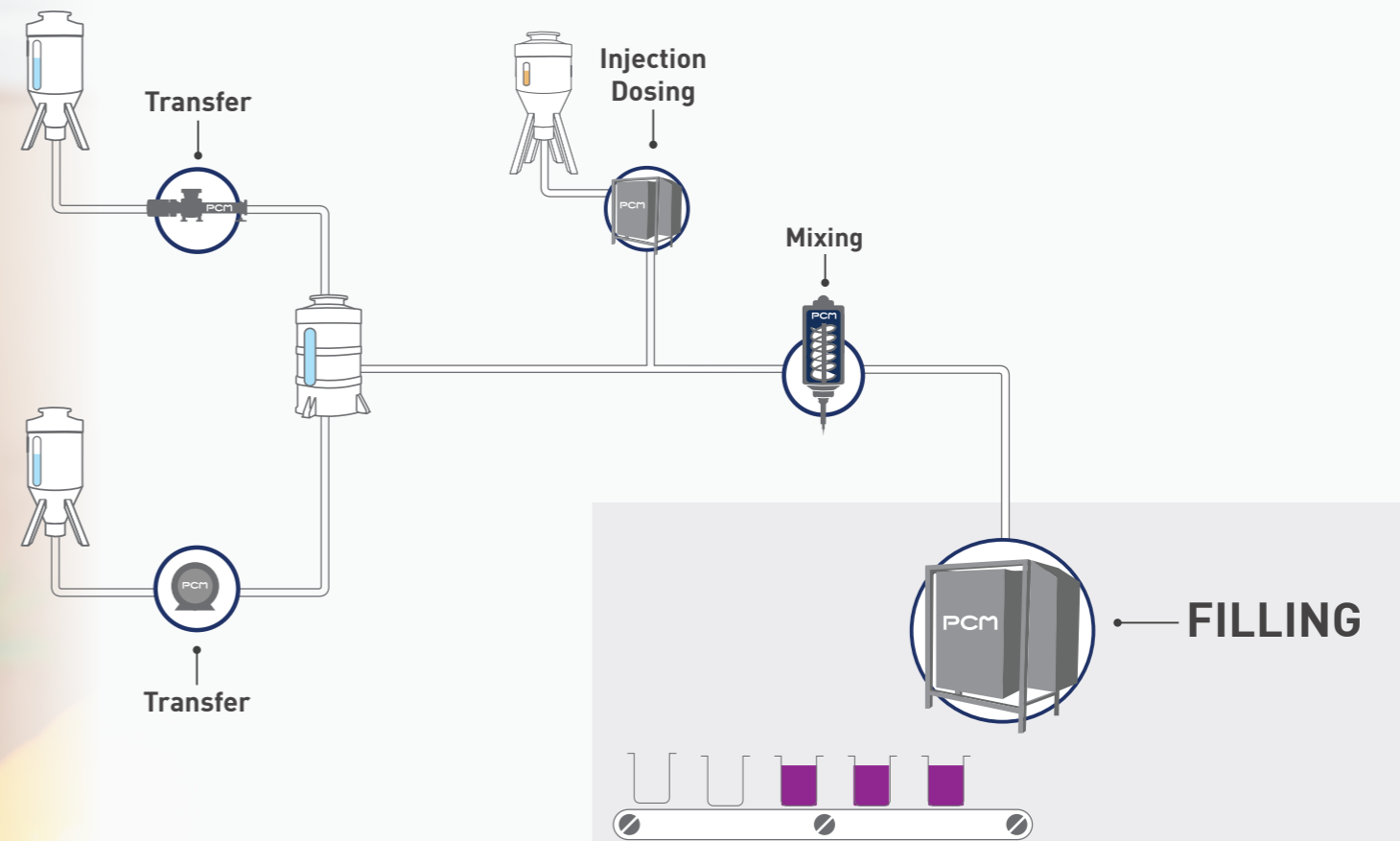

FILLING

The control of a clean and accurate dosage

Filling refers to the act of filling or dosing into any type of container intended for the final consumer or for use in collective catering.

The implementation of innovative agri-food products requires the availability of a high-performance filling solution that will fulfil with the complexity of mixtures, recipes and packaging techniques. Today, creativity in terms of containers and the diversity of textures to be packaged seems limitless. PCM filling systems are designed to provide the versatility and precision required for these critical operations.

PCM filling systems offer maximum volumetric versatility. You can fill containers of any shape and size, while varying the filling volume considerably from one cycle to the next. The same system can therefore be adapted to fill a wide variety of ingredients: from liquid flavours to the most viscous jams, from sticky caramels to sauces of various sizes.

- PCM Dosityfill
- PCM Additivefill

DIAPHRAGM NOZZLE	MULTI-OUTLET DIAPHRAGM NOZZLE	METAL/METAL NOZZLE	UMBRELLA NOZZLE	WHOLE WAY NOZZLE	SUCKBACK NOZZLE	SMALL CAPACITIES SUCKBACK NOZZLE
Technically simple, no dripping	Prevents foaming thanks to multi-outlets	Nozzle nose seal suitable for liquids	Good distribution in the container	Large chunk passage suitable for viscous fluids	Avoids contamination on the container, "rising particles at the end of nozzles"	Pull the string up into the nozzle body at the end of the dosing process
Liquid, viscous, non stringy products without pieces	Liquid, viscous, non stringy products without pieces	Liquid, viscous ingredients with pieces	Liquid, non-viscous ingredients with pieces	Viscous, non-sticky ingredients with pieces	Viscous, sticky, stringy ingredients with pieces	Sticky and stringy products, without pieces
Béchamel, fresh cream, milk	Seeded cheese, soups, tray bottom filling	Sauces with markers, bottom of pot with markers	Jams, rice pudding, potatoes in sauce	Convenience food (ratatouille, gratin dauphinois), canned fruit salad, filling tube or pot with clay paste	Semi-solid stringy products (prunes, tomatoes)	Caramel, chocolat, honey

PCM DOSYFILL

Dosing and filling solutions adapted to your products packaging

PCM Dosityfill filling system is ideal for handling viscous or fragile products with or without markers, no matter the containers.

SYSTEM BENEFITS

A "CUSTOMIZED" SOLUTION FOR YOUR APPLICATIONS

- Can be adapted to various containers, products or existing production lines
- Two available dosing technologies, PCM Moineau™ or PCM Dosys™, to meet the requirements of our customers (doses, cadences, flowrate...)
- Wide range of filling nozzles depending on the products to package (stringy, viscous, large pieces...)

DIVERSITY OF CONTAINERS & APPLICATIONS

- Pouches (sauces for out-of-home catering)
- Buckets (fruits & vegetables preparation)
- Bags (minced meat)
- Pots (fresh dairy products) or bottom pots (multi-layers preparations)
- Thermoformed containers (convenience food)
- Flacons (cosmetics)

100% RELIABLE & REPEATABLE

- Dosys™ technology (see page 7) or Moineau™ technology (see page 6)

HYGIENIC

- Hygienic design of components
- Cleaning in place of the overall system, whatever the proposed solution



EXAMPLE OF REALIZATION

PCM DOSYFILL - Filling of various cosmetic products on flasks

Process

- Doses from 9 to 180ml [0.0024 to 0.047 USGAL]
- 30L [7.93 USGAL] hopper racking

Construction

- 1 Dosys™ technology pump
- Brushless actuator
- 1 pinching nozzle (4mm [0.16 inch] diameter) + 2 static nozzles (4/6 mm [0.16/0.24 inch] & 6/8 mm [0.24/0.31 inch] diameter)
- Integrated cabinet and control panel
- "Top dosing" foot pedal control

EXAMPLE OF REALIZATION

PCM DOSYFILL - Filling of a viscous preparation with pieces on bags or Euro buggies

Process

- Dosing on two stations in alternating mode
- Doses from 10 to 15Kg [22 to 33 lbs] (bags) or 200Kg [441 lbs] (E-buggies)
- Hopper racking
- Dose control by weighing: pump controlled by the scale to reach the desired setpoint
- Integration of a CIP pump
- Cleaning in place of the overall system (excluding hopper)

Construction

- 1 Hycare™ hygienic pump (Moineau™ technology)
- Brushless actuator
- 2 sleeve nozzles (51 mm [2 inch] diameter) mounted on retractable support arm
- Integrated cabinet and control panel
- 1 push button dispensing



EXAMPLE OF REALIZATION

PCM DOSYFILL 3 HEADS - Filling of liquid sauces with or without pieces in preformed pots

Process

- Doses from 15 to 60gr [0.03 to 0.13 lbs]- cadence from 8 to 10 strokes/mn
- Stroke by stroke dosing
- Displacement, on 1 axis, of the conditioning nozzles through Brushless actuator - 7 steps
- "Parking" position for nozzle priming and cleaning
- Cleaning in place of the overall system
- Integration into the existing customer conditioning line

Construction

- Compact and monobloc unit
- 3 Dosys™ technology pumps
- Brushless actuator
- 3 whole way nozzles (12 mm [0.47 inch] diameter)
- Integrated cabinet and deported control panel for operators



PCM ADDITIVEFILL

Micro dosing solutions for liquid ingredients

PCM Additivefill skid is designed for **liquid homogeneous products dosing and filling in any types of containers**. This filling system is the ideal solution for dairy industries for dosing small doses of rennet in the bottom of yoghurt pots.

SYSTEM BENEFITS

A SOLUTION ADAPTED TO YOUR APPLICATIONS

- Can be adapted to various containers and customers processes
- Two available dosing technologies, PCM Dosys™ or diaphragm MDS (Synchronized multi dosing heads) to meet customer requirements. The choice of technology will depend on the desired accuracy, number of flavours, cadences and doses.
- Dosing control with many capacity of several different products in a single cycle
- Compact and mobile solution, can be easily integrated on new or existing installations

DIVERSITY OF CONTAINERS & APPLICATIONS

- Pots (aroms, colorings, additives)
- Bottom of pots (rennet)

100% RELIABLE & REPEATABLE

- Dosys™ technology (see page 7)

HYGIENIC

- Hygienic design of components
- Cleaning in place of the overall system



EXAMPLE OF REALIZATION

PCM ADDITIVEFILL - Dosing of rennet (homogeneous liquid) at the bottom of pots

Process

- Doses: 1cc - cadence 160 pots/mn
- Product suction directly into the drums positioned on the frame
- Dosing synchronization through the conditioning machine
- Rennet dosing directly into the pots / Cycle synchronized for the two dosing heads
- Automatic adjustment of doses according to the selected recipe
- Automatic end product detection in cans
- Cleaning in place without dismantling

Construction

- Compact unit
- 2 Dosys™ technology pumps
- Brushless actuator
- Vertical pump configuration
- Suction pipe adapted to the container and product level sensor
- Cleaning sleeve for suction pipe
- Integrated control cabinet with control panel

EXAMPLE OF REALIZATION

PCM ADDITIVEFILL - Dosing of aroms in pots

Process

- Doses from 0,8 to 1,4 cc - cadence 30 strokes/mn
- Product suction directly into the drums positioned on the frame
- Dosing synchronization through the conditioning machine
- Dosing of aroms directly into the pots / Dosing cycle synchronized for the 20 heads
- Dose control by manual adjustment of the diaphragm stroke
- Cleaning in place without dismantling (closed circuit), suction of the solution from the tanks

Construction

- Compact and mobile unit
- 1 MDS dosing unit with 20 heads
- Diaphragm metering heads with a needle valve at the inlet and a ball valve with truncated conical spring return at the outlet
- Same drive for the 20 heads by rotary cylinder with pneumatic actuator
- 1 distribution plate equipped with 20 static nozzles
- 1 cleaning solution recovery tank fixed on the frame
- Flexible pipe sets between the supply and dosing units
- Electropneumatic control cabinet



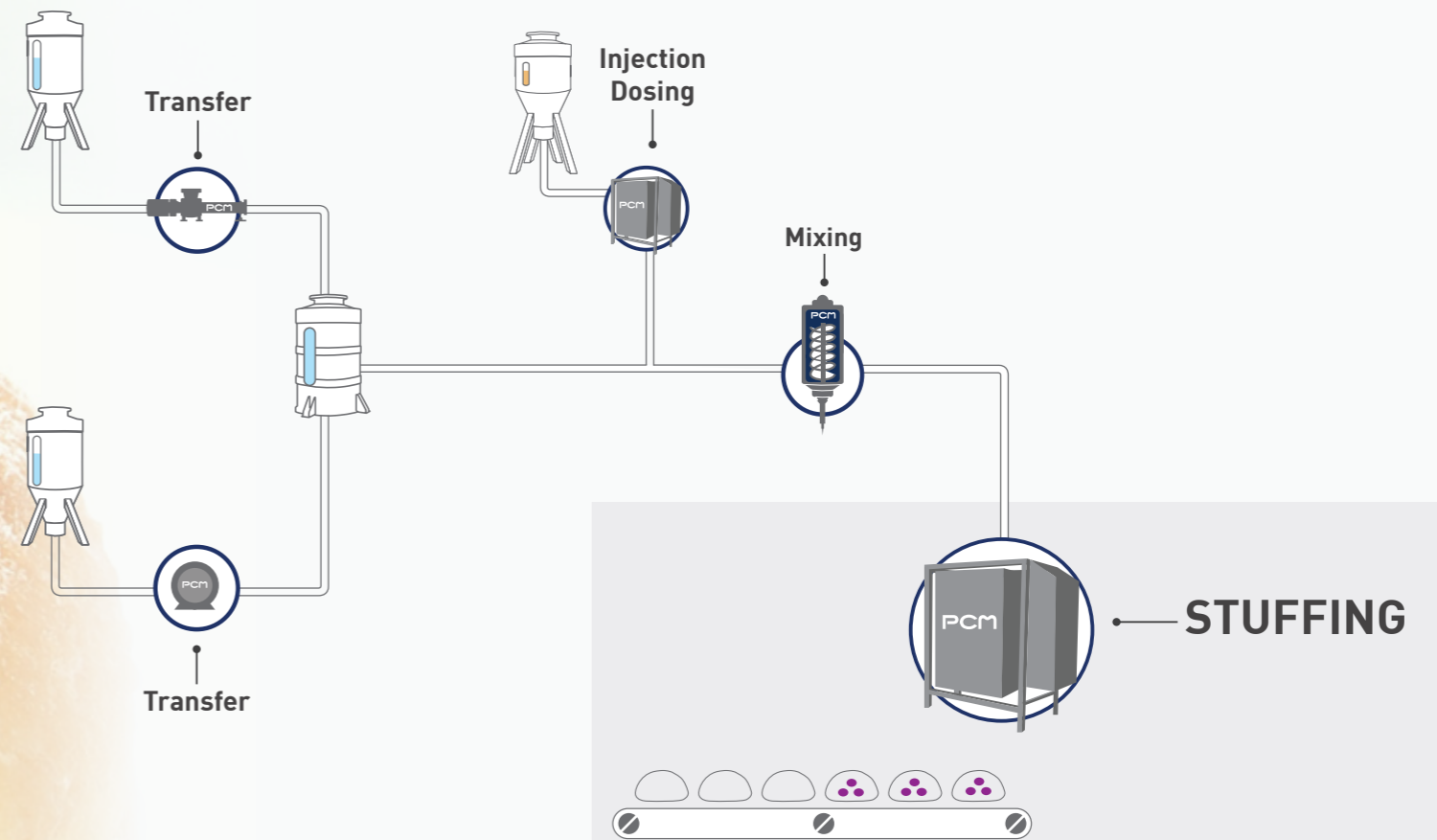

STUFFING

Freedom to be creative: put ideas into production through versatility and maintaining the integrity of the ingredients

Stuffing refers to the action of injecting a dose of an ingredient into a food preparation.

Many applications of stuffing ingredients, often viscous (fruit preparation) or stringy (caramel), are used in the bakery and pastry sector, such as for example in the manufacture of bread rolls feeding with jam or in the production of profiterol with cream. But there are also applications for stuffing liquid doses to flavour preparations.

To meet these constraints, PCM has different transfer and dosing technologies coupled with quilting systems (stuffing needles).

- PCM Dosefeed
- PCM Additivefeed

SINGLE OR MULTIPLE NEEDLES	SUCKBACK NOZZLE WITH NEEDLES
Possibility to orient the right or lateral injection jet One or more outlets at the end of the needle	Cleanliness of the stitching thanks to product suckback
Liquid ingredients Bread roll aromas, fruit pulp in "donuts"	Liquid ingredients Injection of flavours, caramel, chocolate, honey

PCM DOSYFEED & ADDITIVEFEED

"Turnkey" solutions for your products stuffing

PCM Dosyfeed system allows viscous and heterogeneous ingredients stuffing such as jam, honey, chocolate in small buns.

PCM Additivefeed system will be more adapted for homogeneous liquid aromas stuffing in various baked preparations.



SYSTEMS BENEFITS

A "CUSTOMIZED" SOLUTION

- Can be adapted to the dimensions of your final products and to the distribution of stuffing ingredients
- PCM Dosys™ or diaphragm MDS (Synchronized Multi Dosing heads) technology meeting the customers requirements (product, cadence, doses...) and a needle system adapted to viscous, stringy, heterogeneous stuffing products...
- Consideration of existing installations, machine dimensions, conveyor widths

100% RELIABLE & REPEATABLE

- Dosys™ technology (see page 7)
- MDS technology (see page 9)

HYGIENIC

- Hygienic design of components
- Cleaning in place of the overall system

Small buns stuffing
2 dosing units and needle system -
PCM Dosys™ technology and nozzle
distribution plate

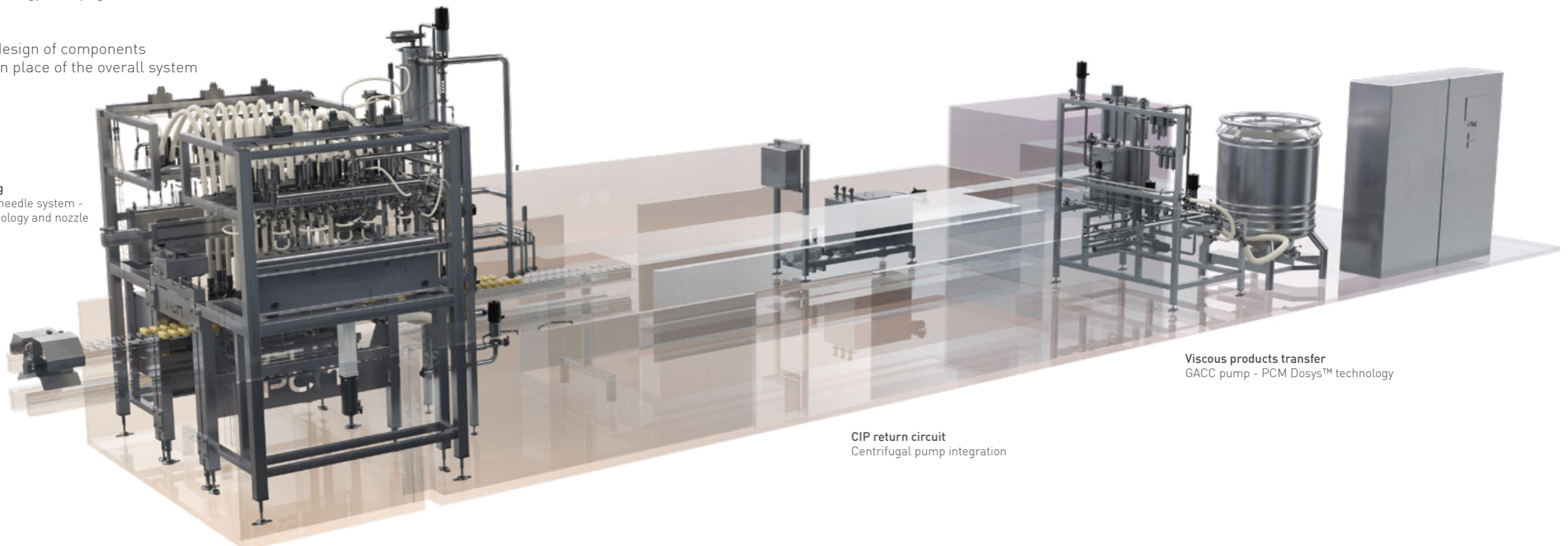

Small buns stuffing with cream
MDS technology and needle system
(PCM Additivefeed)

EXAMPLE OF REALIZATION

PCM DOSYFEED 22 HEADS - Small milk rolls stuffing with viscous products

Process

- Doses: 3 gr/rolls [0.007 lbs] - machine cadence: 24 000 products/h
- Container unloading and transfer of the product to a buffer tank
- Container changeovers without production shutdown
- Product temperature retention throughout the process
- Stuffing of 22 rolls simultaneously
- Synchronization of the stitching with the conveyor
- Rolls detection to avoid the dosing in the absence of products on the conveyor
- Cleaning in place of the overall installation

Construction

- 1 Dosys™ technology GACC pump for the containers unloading
- 2 dosing units including 11 Dosys™ technology pumps with common Brushless actuator
- 2 nozzle distribution plates for 2 x 11 rolls simultaneous stuffing
- 22 suckback nozzles including for each 11 needles for the stuffing distribution
- 3-axis manipulator to handle the needle plate
- Double jacketed collector and process piping for temperature retention
- Optical sensor for rolls detection
- 2 CIP tanks for nozzle distribution plate cleaning and CIP return tank
- 1 utility package for CIP, air, hot water / 1 centrifugal pump for CIP return
- Sensor for product presence, temperature, level and pressure

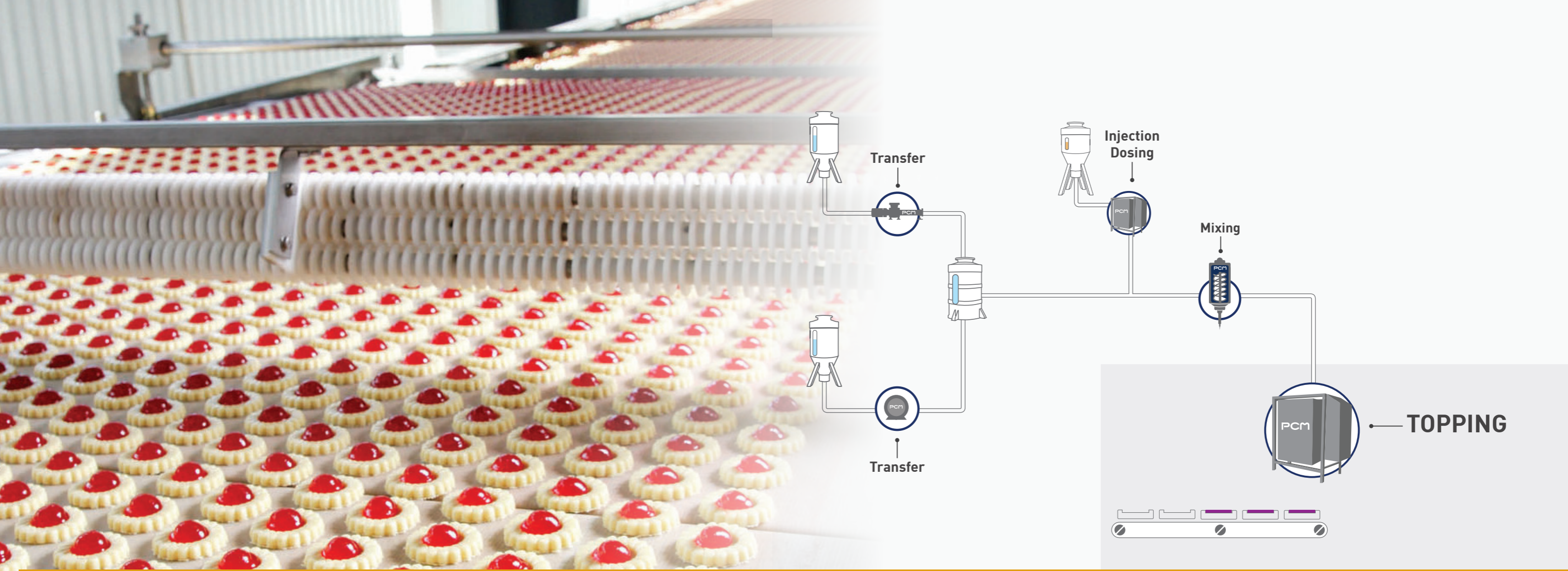

TOPPING

An ultimate and delicate step in the finalization of your recipes

Topping means the action of depositing a dose of ingredient to partially or completely cover a food preparation.

This final step is complex because it finalizes your preparation, it must not risk any imperfection.

For this delicate step, the dosing and transfer technologies are the same as in previous applications but differ by the use of specific nozzles.

- PCM Dosytop

MULTI-OUTLET DIAPHRAGM NOZZLE	UMBRELLA NOZZLE	WHOLE WAY NOZZLE	SUCKBACK NOZZLE	SMALL CAPACITIES SUCKBACK NOZZLE
Prevents foaming thanks to multi-outlets	Good distribution and dispersion inside the container	Large chunk passage suitable for viscous fluids	Avoids contamination on the container, "rising particles at the end of nozzles"	Pull the string up into the nozzle body at the end of the dosing process
Liquid, viscous, non stringy products without pieces	Liquid, non-viscous ingredients with pieces	Viscous, non-sticky ingredients with pieces	Viscous, sticky, stringy ingredients with pieces	Sticky and stringy products, without pieces
Sauce coating on solid, container bottom coating	Liquid sauces	Jams, chicken or tuna crumbs on sandwiches, Bolognese sauce	Semi-solids stringy products: tomatoes	Caramel, chocolate, honey topping

PCM DOSYTOP

Topping solutions adapted to the finalization of your recipes

PCM Dosytop is the ideal system for the topping of viscous and/or heterogeneous ingredients on various food preparations.

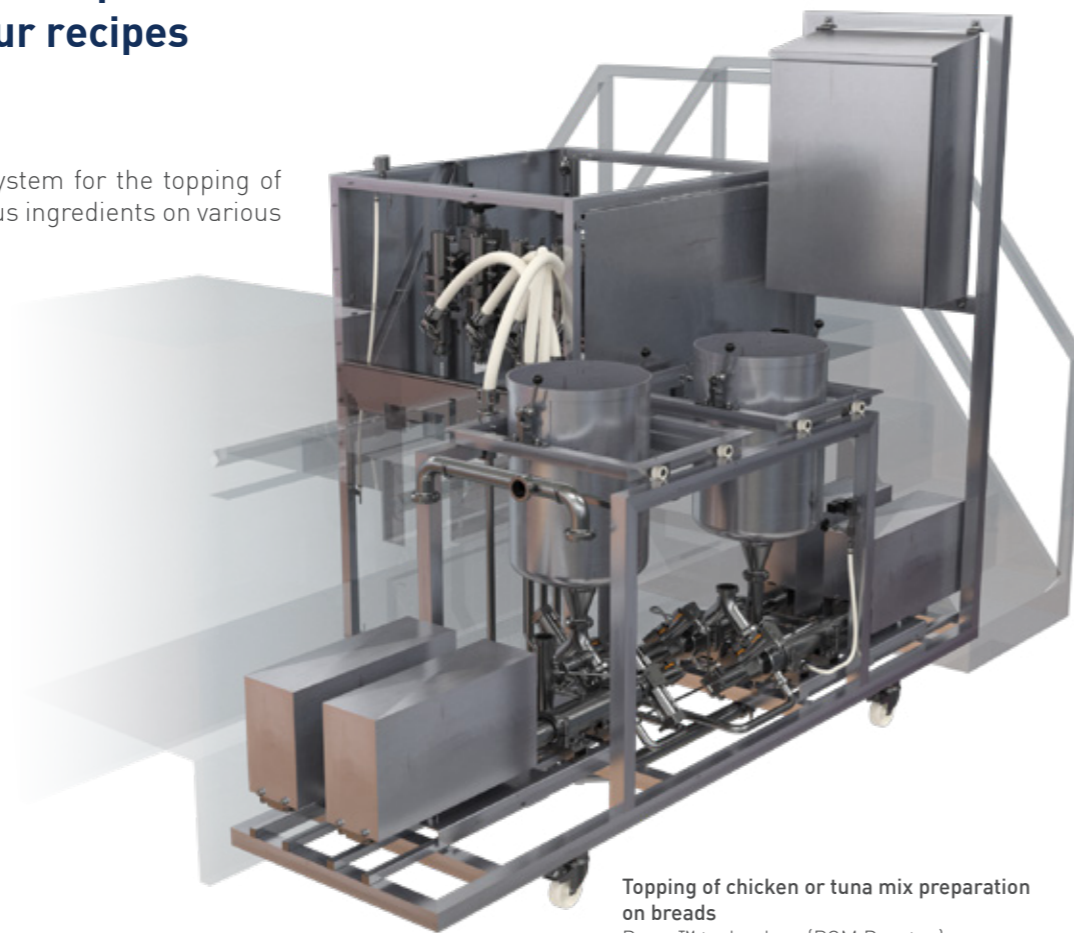

Topping of chicken or tuna mix preparation on breads
Dosys™ technology (PCM Dosytop)

SYSTEM BENEFITS

A "CUSTOMIZED" SOLUTION

- Can be adapted to the dimensions of your final products in any type of containers and to the topping ingredients
- A PCM Dosys™ or PCM Moineau™ technology meeting the requirements of customer processes (products, cadences, doses, ...) and a topping system adapted to viscous, stringy, heterogeneous coating products
- Consideration of existing installations, machine dimensions, conveyor lengths

DIVERSITY OF PRODUCTS/APPLICATIONS

- Biscuits, cakes - Application of jam, caramel, chocolate,...
- Convenience food - Coating of preparations with sauces, creams, vinaigrettes,...
- Bread, Viennoiserie - Application of mixes of preparations on sandwiches, icing

100% RELIABLE & REPEATABLE

- Dosys™ technology (see page 7) or Moineau™ technology (see page 6)

HYGIENIC

- Hygienic design of components
- Cleaning in place of the overall system

EXAMPLE OF REALIZATION

PCM DOSYTOP 4 HEADS - Topping of chicken or tuna mix preparation on breads

Process

- Doses from 28 to 60gr/bread [0.06 to 0.13 lbs]- machine cadence: 3500 breads/h
- Manual loading of the customer preparations directly on the hoppers
- Automatic product priming to the conditioning nozzles
- Automatic dose adjustment through recipes management
- Top dosing when the cells detect the presence of bread
- Simultaneous topping of the mix preparation with 4 heads
- Manually vertical and lateral adjustment of conditioning nozzles
- Detection of low tank level for hopper loading or end of production
- Cleaning in place (excluding hoppers) with CIP collector to be positioned at the nozzle outlet

Construction

- 2 x 50L [13.2 USGAL] loading tanks with covers
- 1 dosing unit equipped with 4 **Dosys™ technology** pumps
- Brushless actuator enabling automatic recipes management
- 1 topping station with 4 whole way suckback nozzles (diameter: 20 mm [0.79 inch])
- Nozzles and handwheels plate for manual adjustment of nozzle positioning
- 316L stainless steel priming and CIP return collector
- 1 electrical panel
- 1 remote pneumatic box fixed on the dosing frame
- Fixed protective housings and access doors for maintenance with safety switches

EXAMPLE OF REALIZATION

PCM DOSYTOP 14 HEADS - Jam topping on rectangular shortbreads

Process

- Product doses: 7gr/biscuit [0.015 lbs]- machine cadence: 450 to 850 biscuits/mn (60 topping/mn max on 14 biscuits rows)
- Product viscosity: from 200 000cpo to 350 000cpo
- Drum unloading (customer product) to the feeding system tank
- The feeding system supplies a transfer pump and limits the incorporation of air into the high viscosity customer preparation. The transfer pump feeds the overall topping system which is equipped with 14 dosing pumps.
- Topping synchronization with the conveyor movement (belt speed)
- The dough pieces are detected by rows. The topping is triggered by the presence of the dough piece.
- Jam topping on 14 dough pieces simultaneously
- Cleaning in place of the overall system (feeding/transfer/topping systems)

Construction

- 1 Viscofeeder equipped with a 500L tank [132 USGAL] and a feeding pressure controller
- 1 **Moineau™ technology** transfer pump (integrated into the feeding system)
- 1 316L stainless steel feeding collector with 14 heads
- 1 topping unit including 14 Moineau™ dosing pumps
- 14 nozzles specifically designed for the topping on biscuits
- 1 conveyor tracking system using Brushless technology and detection cells
- 1 CIP return collector equipped with 14 check valves
- CIP equipment: 2 centrifugal pumps for CIP suction/discharge and valve sets

CHOOSE YOUR APPLICATIONS

and create your combinations...

EXAMPLE OF A COMBINATION OF FUNCTIONS

Industrialization of stirred yoghurts production (High production cadences)

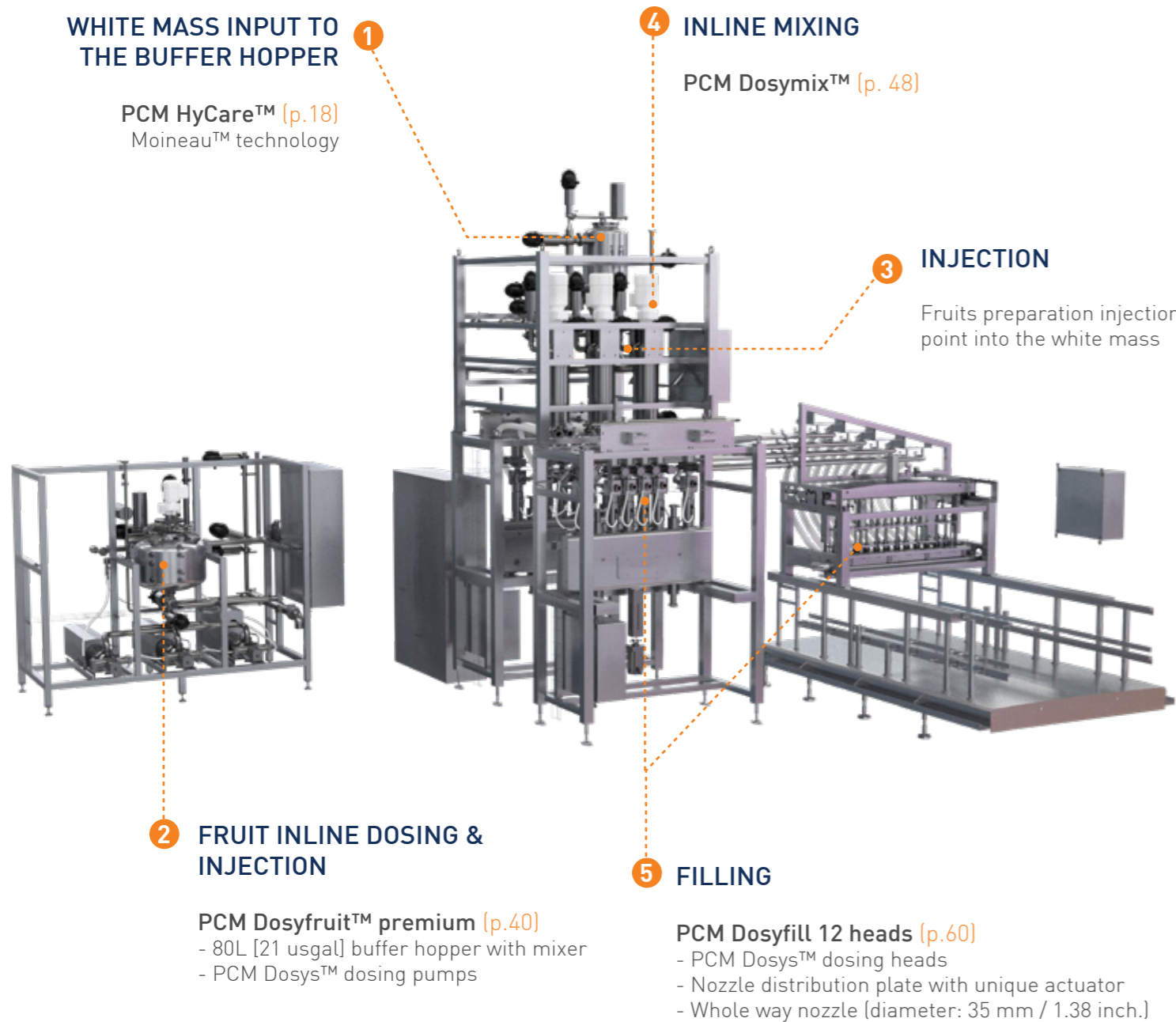

EXAMPLE OF A COMBINATION OF FUNCTIONS

Artisanal production of yoghurts or stirred yoghurts (Versatility, small production batches, frequent recipes changeovers)

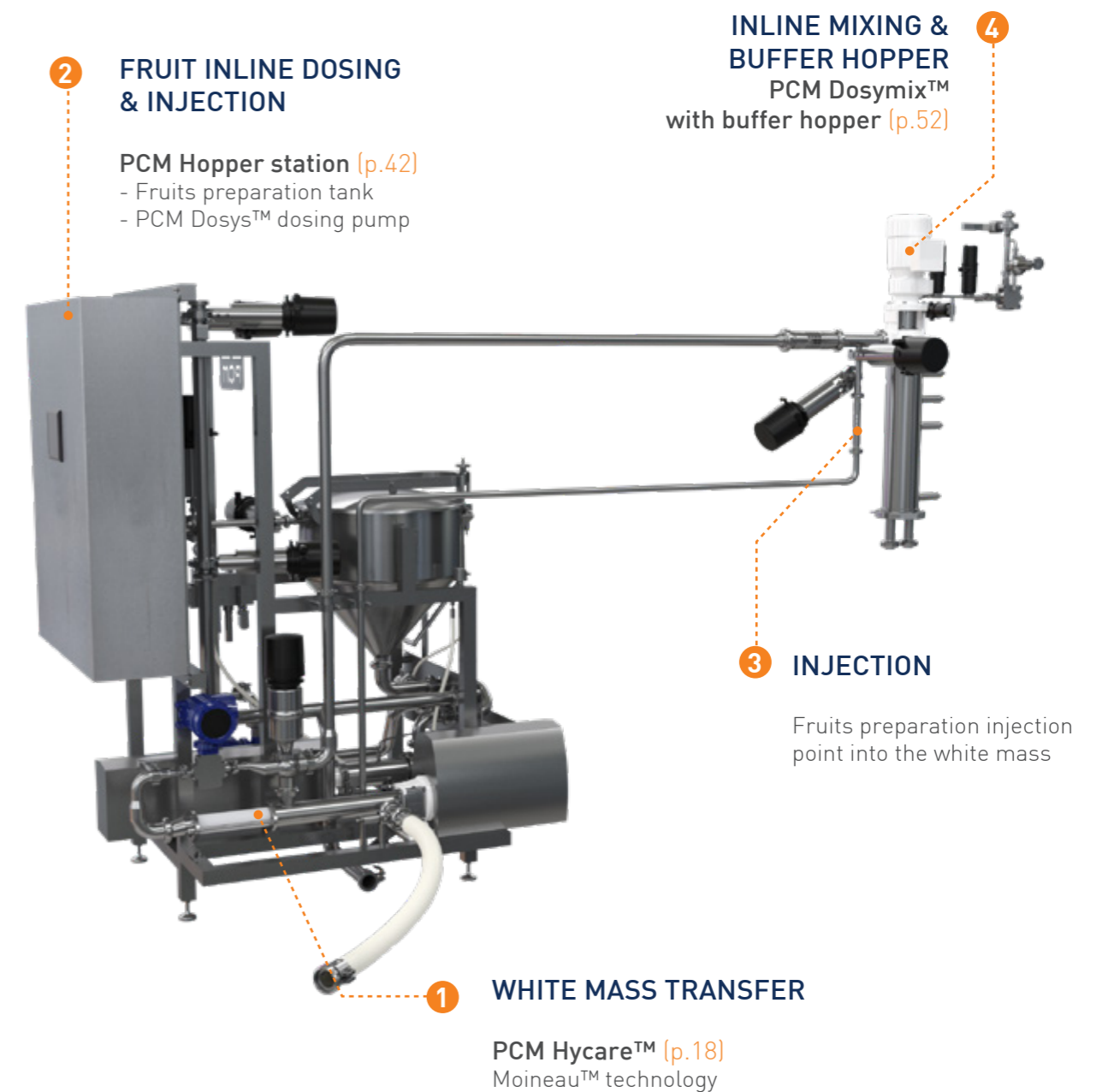



AT YOUR SERVICE

In order to provide the best use of our pumps and pumping systems, we offer a wide range of pre- and post-sales services.

All of our services are designed with one goal in mind: optimising the performance of PCM pumps and systems. From preventive maintenance to spare parts management, from equipment upgrading to training, we strive to best contribute to the productivity of our customers.

› EXTENDED WARRANTY

The extended warranty ensures:

- an extension of our guarantee according to our General Sales Conditions,
- the best solution for delayed installation or commissioning cases,
- the peace of mind at a reasonable cost.

Our extensive service includes also an extension for the general guarantee conditions for a period from one to four years according to your requirements.

› TESTS

To ensure the performance and lifespan of a pump or a system, it is vital that the equipment is engineered to meet the needs of the materials being handled. That is why we provide a wide offer of tests:

- chemical compatibility tests,
- viscosity tests,
- abrasiveness tests.

› TRAINING

In order to support and train the professionals who handle our pumps and systems, we can arrange training sessions either on customer or PCM site.

The use of achieved knowledge enables the participants of the training to maintain the value of the pump or system to minimise the consequential costs for maintenance or service even more.

› MAINTENANCE, REPAIRING & UPGRADE

We offer a full range of services to ensure optimum operation of your pumps as well as time and cost savings.

Maintenance services for PCM pumps are provided by our highly trained engineers. This ensures that pumps and systems are maintained at optimal operating levels. Our careful monitoring and expertise helps to minimise production downtime and increase the global run life of the system.

We provide a wide range of after-sales services:

- maintenance on customer's site,
- PCM workshop maintenance,
- maintenance contracts,
- mechanical seals and rotors refurbishment,
- systems upgrade.

› SPARE PARTS

Thanks to our worldwide network of sales agencies and distributors, you can obtain genuine PCM spare parts quickly. Using PCM spare parts ensures that PCM products last as long as possible, benefit from warranty protection and maintain their CE conformity until their end of life.

PCM experts are dedicated to spare parts and answer your request in the shortest time. Thus, available standard PCM spare parts can be delivered within 24hrs.

› INSTALLATION AUDITS

The Life Cycle Costs audit will optimise the use of your pump while reducing costs related to inefficiency, rationalising your stock of spare parts and controlling your overall costs.

Our extensive service includes:

- a complete inspection of your facilities,
- an analysis of your spare parts consumption,
- a detailed report and our recommendations to help you optimise your costs.

› COMMISSIONING

PCM pumps and systems are simple to use and efficient as long as they are installed and commissioned properly.

Through pre-operational checks and close monitoring of all equipment, our installation services implement stable and secure production.

Our installation services take the guesswork out of integrating a new pump into an existing system or installing a new pump from scratch. We provide start-up assistance, system integration engineering and training for operators.

