



Instruction Manual

Alfa Laval GJ A6



Covering:
Standard Machines
First published: 2015-07

ESE032025-EN1 2015-07

Original manual

The information herein is correct at the time of issue but may be subject to change without prior notice.

1. EC Declaration of Conformity	4
2. Safety	5
2.1. Important Information	5
2.2. Warning Signs	5
2.3. Safety Precautions	6
3. Introduction	7
3.1. Description	7
3.2. Intended Use	7
3.3. Patents and Trademarks	7
3.4. Marking	7
4. Installation	8
4.1. Unpacking/Delivery	8
4.2. Installation	9
4.3. Recycling Information	11
5. Operation	12
5.1. Operation/Control	12
5.2. Trouble Shooting	13
5.3. Cleaning Solution Leakage	14
5.4. Poor Cleaning Performance	15
6. Maintenance	16
6.1. General Maintenance	16
6.2. General Dismantling Setup	17
6.3. General Dismantling	18
6.4. Inspection and Service of Components	19
6.5. Reassembly	22
7. Technical Data	25
7.1. Technical Data	25
7.2. Performance Data	26
7.3. Dimensions	27
7.4. Trax Simulation Tool	28
8. Parts List and Service Kits	29
8.1. AL GJ A6 View	29
8.2. Assembly Drawings - 1 & 2	30
8.3. Assembly Drawings - 3, 4, 5 & 6	31
8.4. Assembly Drawings – 7 & 8	32
8.5. Assembly Drawings – 9 & 10	33
8.6. Assembly Drawings – 11, 12, 13 & 14	35
8.7. Assembly Drawings – 15 & 16	37
8.8. Assembly Drawings - 17 & 18	38
8.9. Assembly Drawing - 19	39
8.10. Parts List	40
8.11. Minor Service Kit	42
8.12. Major Service Kit	45

EC Declaration of Conformity

The designated company

Alfa Laval Tank Equipment Inc.

Company name

604 Jeffers Circle – Exton, PA – 19341, United States

Address

+1 610 408 9940

Phone no.

hereby declare that

Tank Cleaning Machine

Denomination

Alfa Laval GJ A6

Type

From serial numbers from A-1500 to A-XXXX

is in conformity with the following regulations and directives with amendments:

- **FDA 21CFR§177 and 174.6**

- **The Machinery Directive 2006/42/EC**

DS/EN ISO 12100:2011

- **The Pressure Directive 97/23/EC**

According to its own volume and the rated pressure range the product is regarded an Article 3, paragraph 3 Equipment

- **The Regulation (EC) 1935/2004 and the Regulation (EC) 10/2011**

Finished articles subject to an overall migration limit of 10 mg/dm² or 60 mg/kg. The following substances subject to limitations are used in the above stated article:

SML:

PEEK 450G (PEEK GLD FG 140):

Diphenylsulphor: 3 mg/kg food

1,4 Dihydroxybenzol: 0.6 mg/kg food

4,4' Defluorobenzopheneone: 0.05 mg/kg food

Migration from the plastic articles has been investigated by calculations as laid down in paragraph (32) in Regulation (EC) No. 10/2011, to control that the migration limits and other requirements are fulfilled. The articles can be used, within its application area, with all type of foods at batch size above 140 kg.*

**Based on worst case scenario = all of the free monomer in the plastic migrates to one batch.*

The person authorised to compile the technical file is the signer of this document.

Executive VP Operations

Title

Andrew Delaney

Name

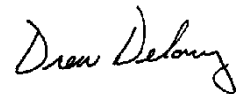

Signature

2015-05-18

Date

Exton, United States

Place



*Unsafe practices and other important information are emphasized in this manual.
Warnings are emphasized by means of special signs.
Always read the manual before using the tank cleaning machine!*

2.1 Important Information

WARNING

Indicates that special procedures must be followed to avoid serious personal injury.

CAUTION

Indicates that special procedures must be followed to avoid damage to the tank cleaning machine.

NOTE

Indicates important information to simplify or clarify procedures.

2.2 Warning Signs

General warning:



Dangerous electrical voltage:



Caustic agents:



2 Safety

All warnings in the manual are summarized on this page.

Pay special attention to the instructions below so that severe personal injury and/or damage to the tank cleaning machine are avoided.

2.3 Safety Precautions

Installation:

Always read the technical data thoroughly. (See chapter 7 Technical Data)

Any tank-cleaning machine can develop a static electricity charge while in operation.

If the tank being cleaned contains a combustible liquid or vapor having a risk of ignition or explosion, it is imperative to have the Alfa Laval Gamajet properly grounded using the provided location on the unit.



Operation:

Always read the technical data thoroughly. (See chapter 7 Technical Data)

Necessary precautions must be taken if leakage occurs as this can lead to hazardous situations.

Always handle lye and acid with great care.

When an Alfa Laval Gamajet is operating, there should be covers over every tank opening.

These covers should be sealed well enough to withstand the full force of the jet striking the cover plate.

If the cleaning solution were hot, corrosive, or toxic, a leak would present a serious hazard to any personnel

in the immediate vicinity or to any exposed electrical equipment.

Warning: Any tank-cleaning machine can develop a static electricity charge while in operation. If the tank being cleaned contains a combustible liquid or vapor having a risk of ignition or explosion, it is imperative to have the Alfa Laval Gamajet properly grounded using the provided location on the unit.



Maintenance:

Always read the technical data thoroughly. (See chapter 7 Technical Data).

Never service the tank cleaning machine when it is hot.

Always use Alfa Laval genuine spare parts.



Transportation of the tank cleaning machine:

Always drain the tank cleaning machine head and accessories of any liquid

Always use original packaging or similar during transportation

3.1 Description

The Alfa Laval GJ A6 is designed for permanent installation and to provide true germ and bacteria-free cleaning to meet the demands of the beverage, food, pharmaceutical and personal care products industries. If the A6 is permanently mounted inside a tank, we strongly recommend inspecting the unit every few hundred hours of operation. (See Section 4.2 - Installation for more information.)

The design of the A6 completely eliminates all areas for potential bacteria growth making it ideal for sanitary cleaning applications. Variable flow rates and a consistent 360-degree spray pattern ensure reproducible and repeatable cycles that provides thorough and verifiable cleaning.

Its compact size fits through a standard 3" sanitary fitting, and its light weight makes for easy handling and maneuverability. The A6 is patent-pending and represents the first valid method of providing true aseptic tank cleaning from a permanently installed impingement cleaner for sanitary applications.

Warning: Under no conditions, whatsoever, should the A6 ever be immersed in anything, unless you have prior approval from Alfa Laval Gamajet Equipment. Failure to comply with this restriction will void the warranty!

In order to handle the broadest possible range of applications, the stainless steel A6 is available with dual or triple nozzles, and an extensive selection of nozzle orifice sizes, stators (non-rotating turbine), and O-ring materials. The nozzles are available in five interchangeable sizes - 3.2mm, 3.8mm, 4.2mm, 4.7mm, and 5.7mm (0.125", 0.150", 0.165", 0.187", and .225"). The Alfa Laval Gamajet wash cycle time can be adjusted for special applications by changing the stators and nozzle orifice size. Interchangeable stators and nozzles are available for either low or high pressures and/or flow rates. The performance capabilities of these options are detailed in Section 7 – Technical Data.

3.2 Intended Use

It is to be verified by the end-user:

- That the tank cleaning machine is in conformity with respect to tank, vessel or container size in which it will be used.
- That the construction materials (both metallic and non-metallic) are compatible with product, flushing media, cleaning media, temperatures and pressure under the intended use.

3.3 Patents and Trademarks

This Instruction Manual is published by Alfa Laval Tank Equipment without any warranty. Improvements and changes to this Instruction Manual may at any time be made by Alfa Laval Tank Equipment without prior notice. Such changes will, however, be incorporated in new editions of this Instruction Manual.

© Alfa Laval Tank Equipment, All rights reserved.

The Alfa Laval logotype is a trademark or the registered trademark of Alfa Laval Corporate AB. "Gamajet" is a trademark or registered trademark of Alfa Laval Tank Equipment. The Alfa Laval GJ A6 product has patent in the US (US 6,123,271; US 6,561,199). Other products or company names mentioned herein may be the trademarks of their respective owners. Any rights not expressly granted herein are reserved.

3.4 Marking

Alfa Laval Gamajet tank cleaning machines are all marked to allow recognition of machine type, machine name, Serial number and manufacturing address. The marking is placed on the body of the tank cleaning machine.

Alfa Laval Tank Equipment
Exton, PA
Patent #: 6,123,271
& 6,561,199

4 Installation

4.1 Unpacking/Delivery

Step 1

CAUTION
Alfa Laval cannot be held responsible for incorrect unpacking.

Check the delivery for:

1. Complete Cleaning Machine
2. Delivery note

Step 2

Remove any packing materials

Step 3

Inspect the tank cleaning machine for visible transport damage

Inspection!

Read the instructions carefully and pay special attention to the warnings! Always check the tank cleaning machine before operation.

4.2 Installation

Step 1



Always read the technical data thoroughly.
(See chapter 7 Technical Data)

Step 2

Assembly

Every Alfa Laval Gamajet is operationally tested before shipment and is ready to run after unpacking. **No assembly is required prior to use.** The Alfa Laval Gamajet has been configured to meet the operating conditions (at the Alfa Laval Gamajet, not at the pump) given to us, e.g. pressure, flow, temperature, cycle time, chemical adders, etc.

Note: Any change to the original operating conditions will affect the Alfa Laval Gamajet accordingly

Warning: Do not force Tee Housing, Pos. 4 to rotate. Doing so may cause damage to the internal components.

Step 3

Inlet Connections

The standard inlet connections for the A6 are 1-1/2" Tubing Butt Weld or 1" Slip-Joint and Retaining Clip. Custom inlet adapters are available.

Step 4

Mounting

Before mounting the A6, make sure the supply line has been adequately flushed. In most applications, the A6 will be mounted with the inlet connection pointing up; however, the A6 will function at any orientation.

Step 5

Location inside Tank

Generally, a single Alfa Laval Gamajet will be positioned in the approximate center of the vessel in order to equalize the cleaning radius in all directions. Some vessels, however, may have specific cleaning problems such as coils or heavy deposits such as the liquid level line (bathtub ring). In these situations the Alfa Laval Gamajet should be located closer to the difficult area for the best cleaning results.

Tanks with internal mechanisms or structures such as an agitator shaft, impellers or baffles will require careful positioning to minimize the "shadow" on areas which do not receive direct jet impact. Sometimes, more than one machine or more than one placement of a single machine may be necessary to completely avoid shadow problems or "striping."

4 Installation

Read the instructions carefully and pay special attention to the warnings! Always check the tank cleaning machine before operation.

Step 6

Entry Openings

When using the A6, the vessels being cleaned must provide entry openings large enough to avoid interference during insertion and removal. The minimum opening size required for the A6 is 71.1 mm diameter (2.80 inches) for free-hand installation, and 95.3 mm (3-3/4") for automated (fixed-centerline) installation.

Step 7

Vessel Drainage

If it is necessary to clean the floor of a vessel, remember that standing liquid will diminish the effectiveness of the Alfa Laval Gamajet by covering any soils underneath. Wherever possible, the tank floor should be pitched toward the drain and the drainage opening should be large enough to eliminate or reduce any liquid buildup or formations of puddles. If gravity alone is insufficient, a scavenger or stripper pump should be connected to the drain to suck out the excess wash fluid. In extreme cases, it may be necessary to mount smaller nozzles on the Alfa Laval Gamajet, or even to operate it intermittently to allow time for draining.

Step 8

Filters and Strainers

All tank cleaning systems should be equipped with a filter or strainer that will trap solids **0.001" (25.4 micron, 550 mesh) or larger**, as these will not pass through the Alfa Laval Gamajet. These particles can become caught in one of the internal passages of the machine, including the internal planetary gearing, and cause it to stop turning or reduce its cleaning effectiveness due to a loss of flow. It will then be necessary to disassemble the Alfa Laval Gamajet and remove the blockage. In recirculated (closed-loop) cleaning or any other application where the cleaning solution may carry abrasive solids in suspension, adequate filtration is a must. These particles can be extremely destructive to the Alfa Laval Gamajet, as well as pumps, valves, and other system components. Filters, properly installed and maintained, will more than pay for themselves with lower overall operating costs in these applications. Furthermore, to ensure that clogged filters or strainers are cleaned, we recommend using automatic self-cleaning models.

Step 9

Capacity of Supply Pump

The A6 can be used with either a centrifugal or positive displacement (constant volume), PD, style pump. In most cases, if the A6 is to be used with a centrifugal pump, the A6 should be configured so that the pump will operate close to its best efficiency point. The end user must, therefore, take all of the plumbing, elevation, and A6 pressure/flow rate requirements into account.

If a PD style pump (i.e. piston pump, plunger pump, or mechanical diaphragm pump, etc.) will supply the wash fluid to the A6, a different set of rules apply. PD pumps are fixed volume pumps whose flow rate is dependent upon the speed of the pump; the pumps also have a pressure rating which is the **maximum** operating pressure.

Note: Do not confuse the maximum operating pressure of a PD pump with the actual operating pressure, the actual operating pressure is dictated by the fixed flow rate of the pump and the A6 and the plumbing system.

If a PD pump is used, the A6 should be sized to, first, match the flow capability of the pump and, second, not exceed the pump's maximum operating pressure (taking the pressure rating of the plumbing system into account, also).

Warning: For high-pressure applications (over 10bar (150 psig)), the pressure of the system must "ramp up" to its operating pressure. If the system experiences a pressure spike or pressure increases at a rate of more than 10bar (150 psi) per second, the machine may be damaged and parts will wear out prematurely. Damage resulting from this water hammer affect is not covered by the warranty.

Read the instructions carefully and pay special attention to the warnings! Always check the tank cleaning machine before operation.

4.3 Recycling Information

- **Unpacking**

- Packing material consists of wood, plastics, cardboard boxes and in some cases metal straps.
- Wood and cardboard boxes can be reused, recycled or used for energy recovery.
- Plastics should be recycled or burnt at a licensed waste incineration plant.
- Metal straps should be sent for material recycling.

- **Maintenance**

- All metal parts should be sent for material recycling.

- **Scrapping**

- At end of use, the equipment must be recycled according to relevant, local regulations. Beside the equipment itself, any hazardous residues from the process liquid must be considered and dealt with in a proper manner. When in doubt, or in the absence of local regulations, please contact your local Alfa Laval sales company.
-

5 Operation

Read the instruction carefully and pay special attention to the warnings!

5.1 Operation/Control

Step 1



Always read the technical data thoroughly. See chapter 7 Technical Data

CAUTION

Alfa Laval cannot be held responsible for incorrect operation/control.

Step 2



Never touch the tank cleaning machine or the pipelines when pumping hot liquids.

Step 3

Initial Startup

Every A6 that ships is accompanied by a Birth Certificate. This document indicates how the A6 performed in our testing tank before it shipped based on the operating conditions supplied to the Alfa Laval Gamajet. To ensure the longest possible life of the A6, please verify the operating conditions and, most importantly, the machine's cycle time. The cycle time can be measured by picking a fixed point inside of a vessel as a reference and timing how long it takes the same nozzle to pass back over that point in the vessel. (This, naturally, will not be the exact same spot because the spray pattern is indexing.) This timed value in seconds corresponds directly to the full cycle time in minutes.

Pay attention to possible faults
Read the instructions carefully

5.2 Trouble Shooting

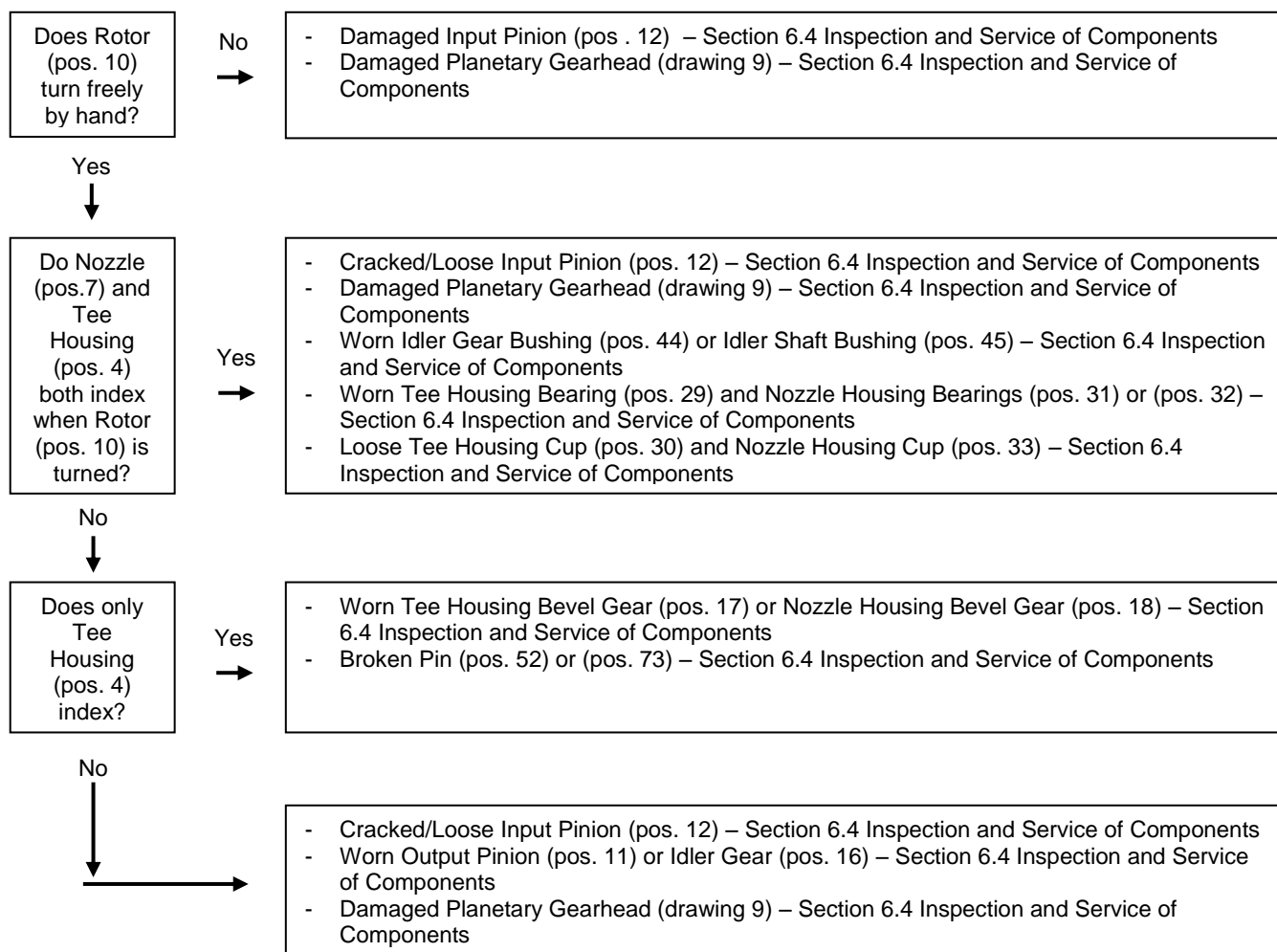

5 Operation

*Pay attention to possible faults
Read the instructions carefully*

Step 1

INSUFFICIENT FLOW

The Alfa Laval Gamajet was configured to meet certain operating conditions outlined at the time of the initial sale, such as flow rate (m³/h)(GPM), pressure (bar)(PSI), temperature, chemical content of the wash fluid, cycle time, etc. If the Nozzle (7) size is too small and/or the opening at the bottom of the Stator (9) is too large, the machine will not turn.

Look for restrictions in the fluid supply such as a clogged filter, kinked hose, or deposits in the piping. Contact Alfa Laval Gamajet Equipment for further assistance or if the machine needs to be reconfigured to work with the new operating conditions.

Step 2

DEBRIS INSIDE

Remove the Collar (8), and then lift out the Stator (9). Look for and remove any debris caught in the Stator (9) and the vanes of the Rotor (10). Remove any material wound around the Rotor Shaft (20). In addition, check for any debris caught in the outlet holes of the Stem (3), the nose of the Tee Housing (4), the Nozzle Housing (5), and the Nozzles (7).

5.3 Poor Cleaning Performance

- Inadequate Flow and Pressure

Check the pressure at the Alfa Laval Gamajet inlet under actual operating conditions. The supply piping and hoses must be large enough to handle the flow rate required for the nozzle size being used to ensure adequate pressure.

Insufficient pressure may also result from line losses when the machine is far from the pump. If this is the case, the line size must be increased accordingly for long runs. Although the Alfa Laval Gamajet will rotate at low flow rates, effective cleaning may require considerably more flow. Proper mechanical operation (the unit turns) is NOT the same thing as effective cleaning (the soils have been removed)! Contact Alfa Laval Gamajet Equipment if assistance is required.

- Chemical Concentration and Temperature

Verify that the cleaning solution is the correct compound and in the concentration needed for the deposit being cleaned. If heating is necessary, also check that the solution is at the proper temperature.

- Plugged Nozzles

Unscrew the Nozzles (7) and inspect for any debris.

- Slow or no Rotation of the Housings

This will result in partial or erratic washing coverage. Refer to previous sections for more information.

- Alfa Laval Gamajet Configuration

Determine if the deposit being cleaned requires greater jet impact or longer jet dwell time (slower rotation) for more thorough scrubbing. Confirm that the Alfa Laval Gamajet nozzle size, turbine, and gearing are correct for the specific application. Refer to the machine's Birth Certificate for specific information regarding its configuration. Contact an Alfa Laval Gamajet Equipment representative if assistance is required.

- Inadequate Drainage

Ensure that the vessel drains the effluent (used wash fluid) as fast as it's being sprayed in through the Alfa Laval Gamajet. The floor of the vessel should be sloped or pitched toward the drain and the drainage opening should be large enough to gravity-drain the effluent from the vessel. If you still have puddling (build-up of the wash fluid so it covers the floor and shields the residues underneath), use some form of pump to remove the effluent.

The Tank Cleaning machine is designed for cleaning in place (CIP). CIP = Cleaning In Place. Study the instructions carefully and pay special attention to the warnings! NaOH = Caustic Soda. HNO3 = Nitric acid.

5.4 Recommended Cleaning

Step 1



Always handle lye and acid with great care.

Caustic danger!



Always use rubber gloves!



Always use protective goggles!

Step 2



Never touch the pump or the pipelines when sterilizing.

Danger of burns!

Step 3



Always rinse well with clean water after using a cleaning agent.

Always rinse!

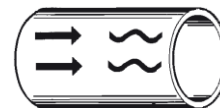

Clean Water

Cleaning agent

NOTE

Cleaning agents must be stored/disposed of in accordance with current regulations/directives.

6 Maintenance

*Maintain the Tank Cleaning Machine with care. Read the instructions carefully and pay special attention to the warnings!
Always keep Minor spare parts kit in stock.*

6.1 General Maintenance

Step 1



Always read the technical data thoroughly. (see chapter 7 Technical Data)

Step 2

Recommended spare parts:

Order service kits from the service kits list

(See 8.11 Minor Service Kit & 8.12 Major Service Kit)

Ordering spare parts:

Contact your local Alfa Laval Sales company.

*Maintain the Tank Cleaning Machine with care. Read the instructions carefully and pay special attention to the warnings!
Always keep Minor spare parts kit in stock.*

6.2 General Dismantling Setup

Step 1

NOTE

A rigorously implemented preventative maintenance program will significantly reduce repair costs over the life of the Alfa Laval Gamajet. The foundation of such a program is regularly scheduled inspections to discover and replace worn or damaged parts before they can cause the failure of other, more costly, components. The inspection intervals required will depend on the severity of the application, but a complete internal inspection at 100 hours of operation is recommended initially.

Step 2

STORAGE

The Alfa Laval Gamajet should be washed out with clean water after each use to remove any foreign material or soft substances left in the machine that may harden during storage and cause the Alfa Laval Gamajet to seize or lock up. A clean water rinse through the Alfa Laval Gamajet will also wash out any residues of chemical cleaners or recirculated wash water that could adversely affect the O-rings during prolonged contact in storage.

Step 3

EXTERNAL INSPECTION INTERVALS

Before every shift, the Stator (9) and the Nozzles (7) should be inspected for debris. Examine the Stator (9) by loosening the removing the Collar (8) and removing the main section of the machine from the Collar (8). Look into each Nozzle (7) for signs of debris or build-up.

Step 4

INTERNAL INSPECTION INTERVALS

An interval of 100 hours is recommended initially. If all of the components are found to be in acceptable condition after the first 100 hours, the Alfa Laval Gamajet may then be inspected and routine preventive maintenance should be performed every 300 to 500 hours of operation, depending on the severity of use.

Step 5

TIPS

All the Bearings, Bushings, Seals and O-rings are wear parts. Ideally, they should all be replaced, as a group, every 300 to 500 hours of operation, depending on the severity of use. If just one Bearing or Seal is worn or damaged, replace both it and its mate, not just the worn or damaged part.

6 Maintenance

Read the instructions carefully. The items refer to the parts list and service kits section.

6.3 General Dismantling

Step 1

Inlet Collar

Remove the Collar Nut (51) with a 5/16" socket.

Loosen the Collar Set Screw (58) with a 5/64" Hex Key, minimum 2 turns.

Remove the Collar (8), Stator (9), Collar Gasket (65), Stator Gasket (70) and Cap O-rings (47) and (48).

Warning: Hold or turn on Stem (3). DO NOT hold or turn on Tee Housing (4) or Base (46). Doing so will damage the gear train.

Step 2

Nozzle Housing

Remove the Nameplate (6) with a 1/4" slotted screwdriver.

Pull the Nozzle Housing Assembly (drawing 18) from the nose of the Tee Housing (4).

Remove the inner Nozzle Housing Bearing (31).

Step 3

Base Assembly

Remove the Base Nuts (59) with a 3/8" Socket, the first set of Base Screw Gaskets (68), Base (46), Ring Gear Spacer (56), and Ring Gear (19) from the Tee Housing (4).

If they did not come off with the Base Nuts (59), remove the Base Screws (53) using a 3/32" Hex Key and the second set of Base Screw Gaskets (68).

Remove the Nut (51) with a 5/16" socket and Screw O-ring (62) from the Output Shaft (37).

Pull out the Idler Shafts (15), Idler Gear Assemblies (drawing 13), and the Output Pinion (11). Unless the Idler Shaft Bushings (45) have obvious wear, leave them on the (15) at this time.

Step 4

Tee Housing

Unscrew the Idler Shaft Base Screws (50) with a 3/16" slotted screwdriver, and remove the Idler Shaft Base (42).

Remove the Tee Housing (4) by pulling it off of the body.

Remove the lower Tee Housing Bearing (29) and Bevel Gear (17).

Step 5

Cap and Stem

Using a 3/32" Hex Key, remove the Cap Screws (71) from the Cap (2).

Remove the Cap (2) and the Body Gasket (66) from the body.

Unscrew and remove the Idler Shaft Base/Stem Screw (50), which holds on the Stem (3).

Pull the Stem (3) and Stem Large gasket (67) from the remainder of the body.

Read the instructions carefully. The items refer to the parts list and service kits section.

6.4 Inspection and Service of Components

Drawing 19

Inlet Assembly

Inspect the trough holes of the Stator (9) to be sure that they are clear.

Inspect Gaskets 65, (70), and (66) and Cap O-rings (47) and (48) for permanent set and/or deterioration. Replace if needed.

Drawings 16, 13

Base Assembly

Inspect the Output Pinion (11) and Idler Gears (16) for worn, damaged, or sharp/pointed teeth. Replace as needed.

Check for signs of scoring on the Idler Shafts (15). Replace as needed.

Inspect all four of the Base Screw Gaskets (68) for permanent set and/or deterioration. Replace as needed.

Examine the Idler Gear Bushings (44) in the Idler Gears (16) and the Idler Shaft bushing (45). The inside diameter of the (44) should not exceed $-.196$ ". If they need to be replaced, remove by pressing them out. The (45) should be tight to the Idler Shafts (15). The thickness of these bushings should not be less than 0.065 ". Replace if necessary.

Check the Ring Gear Spacer (56) for signs of deterioration, scoring, or thinning. Replace if the thickness is 0.171 " or thinner.

Drawing 9

Planetary Gear Train Assembly

General Disassembly and Inspection

Tip: Disassemble the Planetary Gear Train Assembly (drawing 9) over a container or a confined space. There are several small components inside of the Gear Train, which may spill out if you are unfamiliar with its contents.

Unscrew the Rotor Nut (57) with a $\frac{1}{4}$ " socket and remove it with the Rotor Gasket (69) from the Rotor Shaft Assembly (drawing 6).

Remove the Rotor Assembly (drawing 8) from the Rotor Shaft (20). If needed, use a slotted screwdriver for assistance.

Using a $\frac{5}{64}$ " Hex Key, loosen and remove the two Planetary Gearhead Screws (54) that hold down the Gearhead Upper Flange Assembly (drawing 1).

Ensuring that the Gear Train Assembly (drawing 9) is oriented with the Rotor shaft (20) up, carefully remove the Gearhead Upper Flange (21) by holding down the (20) with one finger and pulling and twisting the (21) from the Gear Train. Applying downward pressure on the (20) ensures that none of the internal gearing is dislodged when the (21) is removed.

Remove the body gasket (66).

Carefully remove all of the internal components of the gearhead by resting the tip of the Output Shaft Assembly (drawing 3) on the table and allowing the Upper Stem (1) and Planetary Ring Gear (23) assembly to slowly drop downward. Holding a finger on the top stage of gears will steady all of the internal components during this process.

After the Upper Stem (1) and Planetary Ring Gear (23) have been lowered to the table, take all of the internal gearing, keeping it in one piece, and set it aside.

Unscrew the other pair of Planetary Gearhead Screws (54) from the Planetary Output Shaft Bearing Housing Assembly (144; drawing 2) using a $\frac{5}{64}$ " Hex Key.

Pull the (144; drawing 2) from the Upper Stem (1).

Remove the Body Gasket (66).

Pull the Planetary Ring Gear (23) from the Planetary Output Shaft Bearing Housing Assembly (144; drawing 2). Do not attempt to twist the (23), the Planetary Gearhead Pin (39) prevents this from happening.

6 Maintenance

Read the instructions carefully. The items refer to the parts list and service kits section.

Drawings 3-5, 9

Planetary Gear Train Assembly

Gearhead Internals & Output Shaft Assembly

Note: The same parts are repeatedly used for all of the stages in the gearhead. It is recommended, but not necessary, to keep the stages in the same order as they are removed.

Warning: If you suspect that (drawing 9) requires service, proceed with caution. If at any time you do not feel completely comfortable servicing (drawing 9), contact Alfa Laval Gamajet Equipment immediately.

Carefully separate the different stages of gears by lifting and removing the Planet Gear Carrier (34) of each stage from the lower stage of gears.

When all of the stages are separated, remove the Washer (24) or (55), Planet Gears (26), and Planet Gear Washers (27). As mentioned before, it is recommended to keep each stage of parts together.

Inspect the Washers (55), (36), (24), and (27) for signs of scoring and decrease in thickness. The (55) should not be less than 0.006" thick, and the (24), (27), and (36) should not be less than 0.0013" thick. Replace if necessary.

Examine all of the (26) for any worn or broken teeth. Also, verify that all of the Planet Gear Bushings (25) are tight inside of each gear. Their inside diameter should not be greater than 0.095". If they need to be replaced, remove by pressing them out.

Check the components of the Planet Gear Carrier Assemblies (drawing 4) and Output Shaft (37). Starting with the Planet Gear Idler Shafts (28), check for signs of scoring and wear. Examine all of the Planet Gear Carrier Pinions (35) for worn or broken teeth. The worn individual components can be pressed out of the Planet Gear Carrier (34) or (37) and replaced with new ones.

However, it is important that all new pieces be fully pressed into and perpendicular to their mates. If you are unable to accomplish this, complete assemblies are available from Alfa Laval Gamajet Equipment.

Inspect the Output Shaft (37) for signs of scoring and wear. Replace (37) if wear or scoring has visually decreased the diameter of the (37).

Examine the Planetary Ring Gear (23) for bent or sharp teeth. Replace if required.

Drawings 1, 6, 8, 9

Planetary Gear Train Assembly

Input Assembly

Inspect the Input Pinion (12) for hairline cracks on the end face or for worn, damaged, or sharp/pointed teeth. The (12) should be tight to the Rotor Shaft (20) and the Input Pinion Thrust Washer (22). Press (12) back onto (20) if it has slipped, or replace if cracked or worn.

Check for signs of scoring and wear on Rotor Shaft (20). Replace as required.

The Pins (73) should be firmly pressed into the Gearhead Upper Flange (21).

The through holes of the (21) should be clear and free of debris.

Inspect the Body Gasket (66) for permanent set and/or deterioration. Replace if needed.

The carbides, (13) and (14), in the Rotor (10) and (21) should protrude slightly. **In addition, their running surfaces should be smooth and free of chips and cracks.**

Drawings 2, 9

Gearhead Lower Flange Assembly

Inspect the Gearhead O-ring (60) for deterioration (hardening/deformation) or damage and replace if necessary.

Check the inside diameter of the Planetary Output Shaft Upper Bushing (38). It should not be greater than **0.380"**. In addition, the distance from top of the flange of the (38) to the top of the (40) should not be greater than **0.058"**. If it needs to be replaced, remove it by pressing it out.

The Pins (73) and (39) should be firmly pressed into the (40).

The Output Shaft Carbide Bearing (41) should be fully pressed into the (40). The (41) will be recessed slightly if properly installed.

Inspect the Body Gasket (66) for permanent set and/or deterioration. Replace if needed.

Read the instructions carefully. The items refer to the parts list and service kits section.

Drawings 17-19

Nozzle Housing

Unscrew the Nozzles (7) with pliers and inspect for debris caught on the Stream Straightener (72) or in the nozzle orifice. The inside diameter of (7) must be smooth, round, and free of damage (especially any nicks) for maximum jet impact. Replace worn or oversized nozzles if the original flow rate and pressure are required.

Inspect the Nozzle Housing Bevel Gear (18) for wear such as sharp/pointed or worn teeth. Replace as required.

Inspect the Nozzle Housing Bearings (32) and (31). Replace if the bearings are scored or grooved on their running surfaces. Clean any deposits from the exterior of bearings and check their fit in the Nozzle Housing Cups (33). While they should turn freely, the bearings should be replaced if the thickness of the **flange** is **0.058"**, or less, to avoid shortening the life of the Bevel Gears.

Inspect the Nozzle O-rings (49) and (61) for permanent set or deterioration. Replace if needed.

Inspect the Tee Housing Nose Gasket (64) for permanent set and/or deterioration. Replace if needed.

Clean any deposits from (33) and examine for excessive wear. Light scoring is acceptable, however, deep or sharp groves will reduce the performance of the Bearings if not replaced. A good maintenance program will require replacing many (33), therefore, it may be worthwhile to make or obtain a press tool for pressing (33) out of (5). The press tool is available from Alfa Laval Gamajet Equipment. Before installing new (33), clean the housing bores and remove any burrs resulting from (33) removal. Press them in so that their flanges are flush against (5).

Drawings 11, 14, 15

Tee Housing

Inspect the Tee Housing (4) for damage to the hole that engages the Ring Gear Drive Pin (52). If the Ring Gear (19) was difficult to remove, check to see if (4) is out-of-round (as the result of an external blow, such as dropping) where the Gear seats. Replace if needed.

Check the water outlets on the nose of (4), they should be free of debris.

Inspect the Tee Housing Bevel Gear (17) for worn, damaged or sharp/pointed teeth.

Inspect the Ring Gear (19) for worn, damaged or sharp/pointed teeth, and for damage to the (52) that engages the hole in (4). Replace if needed.

Inspect the Tee Housing Bearings (29). Replace if the bearings are scored or grooved on their running surfaces. Clean any deposits from the exterior of (29) and check their fit in the Tee Housing Cups (30). While they should turn freely, (29) should be replaced if the thickness of the **flange** is **0.058"**, or less, to avoid shortening the life of the Bevel Gears (17) and (18).

Clean any deposits from (30) and examine for excessive wear. Light scoring is acceptable, however, deep or sharp groves will reduce the performance of the Bearings if not replaced. A good maintenance program will require replacing many (30), therefore, it may be worthwhile to make or obtain a press tool for pressing (30) out of (4). The press tool is available from Alfa Laval Gamajet Equipment. Before installing new (30), clean the housing bores and remove any burrs resulting from (30) removal. Press them in so that their flanges are flush against (4).

Drawings 7, 10, 12, 14

Stem and Idler Shaft Base

Inspect the water outlets of the Stem (3), they should be free of debris.

The Pin (73) should be firmly pressed into the (3).

Inspect the Stem-Idler Shaft Gasket (63), the Stem Large Gasket (67), and the Screw O-rings (62) for permanent set and/or deterioration. Replace if needed.

The Output Shaft Lower Carbide Bearing (43) should be fully pressed into the Idler Shaft Base (42). The (43) will be recessed slightly if properly installed.

6 Maintenance

Read the instructions carefully. The items refer to the parts list and service kits section.

6.5 Reassembly

General Notes

All parts must be cleaned thoroughly before reassembling. Any deposits remaining on the parts can cause difficult disassembly the next time the Alfa Laval Gamajet needs servicing. Also, it may cause misalignment of parts and the potential for premature failure.

Unless otherwise stated, apply a dab of a food grade **anti-seize compound** to all threads when reassembling; this will prevent galling of threads and ease any future disassembly.

To ease installation of all O-rings, they should be lubricated prior to reassembly. Lithium-based soap grease is acceptable, for Viton® O-rings; however, a Silicon based lubricant must be used for EPDM O-rings. In either case food grade grease may be used.

Drawings 1-9

Gear Train

Push the Ring Gear (23) over the Output Shaft Bearing Housing (40), being sure to align the keyway of the (23) with the Gearhead Pin (39).

Position the Body Gasket (66) over the (40). Align the smallest holes in the gasket over the small through holes of the Gearhead Screws (54).

Place the Upper Stem (1) {8 holes down toward the (40), 6 holes up} over this assembly being sure to align the Pins (73) with proper holes in the (1).

Pass the (54) through the (40) and, using a 5/64" Hex Key, **lightly** tighten them into the (1). The (54) do nothing more than hold the gear train assembly together during service and inspections.

Put the Output Shaft Washer (36) onto the Output Shaft (37). Insert this assembly into the (23) and pass the (37) through the center of the (40) until it bottoms out on the Output Shaft Upper Bushing (38).

Tip: To ease in the installation of the internal gearhead components, the gearhead assembly will have to be supported such that the Output Shaft (37) rests at the bottom of the (23). Take the Tee Housing (4) and place it on the table, Planetary Ring Gear (23) end down. Place the Collar (8), inlet down, on top of the (4). Now, take the gearhead assembly and place it onto this support such that the (37) passes through the center of the (8) and the (40) rests on the (8).

Using a small shaft, such as a Hex Key, as a guide, drop the Planet Gear Washers (27) and then the Planet Gear Assemblies (26; drawing 5) onto each of the bottom Planet Gear Idler Shafts (28).

Place the bottom Planetary Gearhead Large Washer (24) over the (26).

Drop the Planet Gear Carrier Assembly (34) into the assembly such that the Planet Gear Carrier Pinion (35) engages with the bottom (26; drawing 5).

Repeat this procedure until the Washers, Gears, and Carriers have been installed in the (23). As stated previously, it is recommended, but not necessary, that the parts be installed back into the gearhead in their original order.

Place the Gearhead Top Washer (55) onto the top layer of (26).

Position the Body Gasket (66) over the Upper Stem (1), aligning the smallest holes with the small threaded holes for the Planetary Gearhead Screws (54).

Install the Rotor Shaft Assembly (20; drawing 6) into the center of the assembly, such that the Input Pinion (12) engages with the top Planet Gear (26; drawing 5).

Drop the Gearhead Upper Flange Assembly (21; drawing 1) over the Rotor Shaft (20). Align the holes in the (21) with the holes in the (1). Pass the second set of (54) through the (21) and, using a 5/64" Hex Key, **lightly** tighten the (54) into the (1).

Place the Rotor (10), with the Carbide Bearing (13) down, over the (20).

Using a 5/16" socket, tighten the Rotor Nut (57) and Rotor Gasket (69) onto the (20).

Read the instructions carefully. The items refer to the parts list and service kits section.

Drawing 10

Stem and Cap

Position the Body Gasket (66) over the Gearhead Upper Flange (21), aligning the smallest holes of the gasket with the Planetary Gearhead Screws (54).

Place the Cap (2) on the Gear Train Assembly (drawing 9), aligning the Pins and holes.

Using a 3/32" Hex Key, screw the Cap Screws (71) into the Upper Stem (1). Tighten in a star pattern.

Place the Stem Large Gasket (67) in the Stem (3).

Attach the (3) to the other end of the Gear Train Assembly (drawing 9) with the Idler Shaft Base/Stem Screws (50) using a 3/16" slotted screw driver. Tighten in a star pattern.

Drawing 14

Tee Housing

Slide the Tee Housing Bevel Gear (17) over the end of the Stem (3). Align the slot in the (17) with the Pin (73).

Place the first Tee Housing Bearing (29) onto the (3).

Push the Tee Housing (4) over it until it is flush and fully seated.

Place the second (29) over the (3) and then push it down into the annular space between the (3) and Tee Housing Cup (30).

Put the Stem-Idler Shaft Gasket (63) over the tip of the (3).

Align the through holes of the Idler Shaft Base (42) with the threaded holes in the top of the (3). Using a 3/16" slotted screw driver, thread Idler Shaft Base Screws (50) into the (3). Tighten in a star pattern.

Warning: Hold or turn on Stem (3). DO NOT hold or turn on Tee Housing (4) or Cap (2). Doing so will damage the Gear Train.

Drawings 18, 19

Nozzle Housing

Place the Inner Nozzle Housing Bearing (31) onto the nose of the Tee Housing (4).

Screw the Nozzles (7) into the Nozzle Housing (5).

Push the (5) onto the nose of the (4). **Rotate the Tee Housing Assembly (drawing 11) slightly to mesh the Bevel Gears (17) and (18). Failure to ensure that the Bevel Gears have properly mated could damage them.**

Place the Outer Nozzle Housing Bearing (32) over the nose of the (4) and push it into the annular space between the (4) and Nozzle Housing Cup (33).

Put the Tee Housing Nose Gasket (64) onto the backside of the Nameplate (6).

Using a 1/4" slotted screwdriver, screw (6) into (4). Alfa Laval Gamajet Equipment recommends using a thread locker product in this sealed area to prevent the nameplate from loosening with time.

6 Maintenance

Read the instructions carefully. The items refer to the parts list and service kits section.

Drawing 16

Base Assembly

If they have been removed, install the Base Screws (53) using a 3/32" Hex Key.

Place the first set of Base Screw Gaskets (68) over the (53).

Insert the Ring Gear (19) into the Tee Housing (4; drawing 11), be sure to align the Drive Pin (52) of (19) with the hole in (4).

Place the Output Pinion (11) {round opening down} onto the Output Shaft (37; drawing 3).

If the Idler Shaft Bushings (45) are still on the Idler Shafts (15), place the Idler Gears (16; drawing 13) over the other end of the (15) {the flange of the Idler Gear Bushings (44) should be on the opposite side of the (45)}. Push the (15) into their respective holes in the Idler Shaft Base (42). Twisting the (4) **slightly** will help the (16) drop into place.

If the (45) are not on the (15), push the (15) into the (42). Then, place the (16) over the (15) {(44) down}. Twisting the (4) slightly will help the (16) drop into place. Finally, push the (45) over each (15).

Using a 5/16" socket, screw the Output Pinion/Collar Nut (51) and the Screw O-ring (62) onto the (37).

Place the Ring Gear Spacer (56) on the Base (46).

Put the (46) back into the (4).

Using a 3/8" Socket, screw the Base Nuts (59) and Base Screw Gaskets (68) onto the (53).

Drawing 19

Stator and Inlet Collar

Rotate the Rotor (10) using a Hex Key. It should spin easily and its veins must not strike the walls of the Cap (2). Continue turning the Rotor. The Nozzle and Tee Housing will slowly rotate if everything has been assembled correctly.

Insert the Stator (9) into the (2).

Place the Collar Gasket (65) over the (2), and the Stator Gasket (70) over the (9). Also, place the Cap O-rings (47) and (48) into the O-ring grooves on the Cap (2). Appropriate O-ring lube maybe required when assembling Collar (8).

Screw on the Collar (8) {hand-tight only}, and tighten the Collar Set Screw (58) with a 5/64" Hex Key. Alfa Laval Gamajet Equipment recommends using a thread locker product on this set screw to prevent the set screw from unthreading.

Put the Screw O-ring (62) over the (58). Then, using a 5/16" Socket, tighten the Output Pinion/Collar Nut (51) onto the (58).

*It is important to observe the technical data during installation, operation and maintenance.
Inform personnel about the technical data.*

7.1 Technical Data

The Alfa Laval GJ A6 Tank Cleaning Machine is a highly efficient machine at a range of pressures and flows. The instruction manual is part of the delivery. Read the instructions carefully.

TECHNICAL DATA

Lubricant Self-lubricating
 Max. throw length 2 – 6 m (6 - 19 ft.)

Pressure

Working pressure 2 – 27+ bar (30 – 400+ PSI)
 Recommended pressure 2 – 10 bar (30 - 150 PSI)

Cleaning Pattern

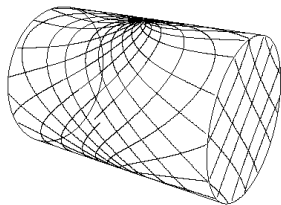

First Cycle

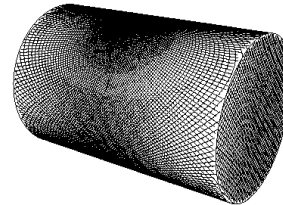

Full Pattern

The above drawings show the cleaning pattern achieved on a cylindrical horizontal vessel. The difference between the first cycle and the full pattern represents the number of additional cycles available to increase the density of the cleaning.

Certificate

2.1 Material Certificate

PHYSICAL DATA

Materials

1.4404 (316L), PEEK (EPDM, FFKM, and FKM available).

Temperature

Max. working temperature 95°C (203°F)
 Max. ambient temperature 140°C (284°F)

Weight 1.8 kg (4 lbs.)

Surface finish 0.5 µm (20 Ra)

Connections

Standard thread 1" slipfit, 1 ½" tri-clamp, 1 ½" tube weld, 1" DIN 1185R1 slip, 1" DIN 1185R2 slip
 Available option 12", 18, 24" inlet connections, 3" CAP, 1 ½" TC inlet

Options

Electronic rotation sensor to verify 3D coverage.

Caution

Do not use for gas evacuation or air dispersion.

7 Technical Data

It is important to observe the technical data during installation, operation and maintenance.
Inform personnel about the technical data.

7.2 Performance Data

It is important to observe the technical data during installation, operation and maintenance.
Inform personnel about the technical data.

Flow Rate

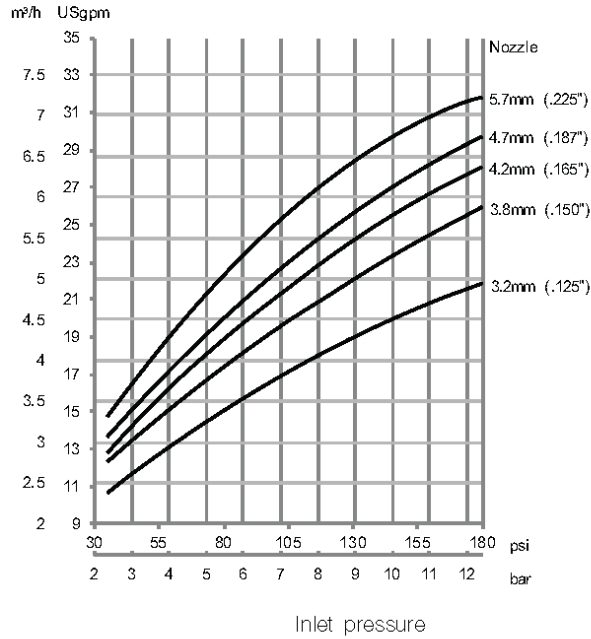

Impact Throw Length

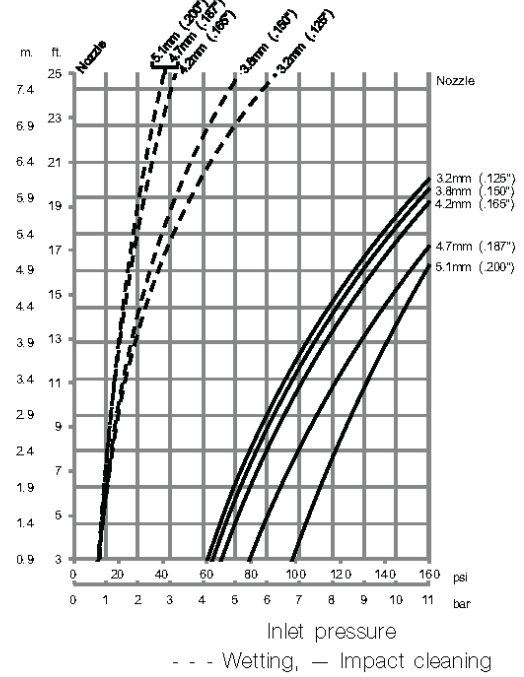

Cleaning Time

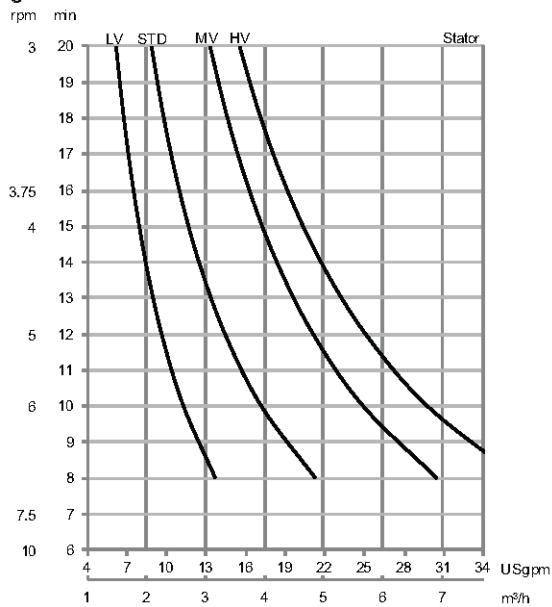

*It is important to observe the technical data during installation, operation and maintenance.
Inform personnel about the technical data.*

7.3 Dimensions

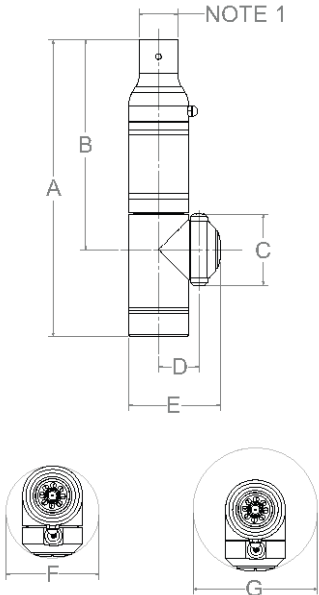

Dimensions

	A	B	C	D	E	F	G
mm	223	158	54	30	68	70	93
in	8.75	6.19	2.1	1.18	2.67	2.72	3.64
NOTE 1: 1" R-CLIP COLLAR OR 1-1/2" BUTT WELD							

7 Technical Data

*It is important to observe the technical data during installation, operation and maintenance.
Inform personnel about the technical data.*

7.4 Trax Simulation Tool

Standard Design

The choice of nozzle diameters can optimize jet impact length and flow rate at the desired pressure. As standard documentation, the Alfa Laval GJ A6 can be supplied with a "Declaration of Conformity" for material specifications.

TRAX Simulation Tool

TRAX is a unique software that simulates how the Alfa Laval GJ A6 performs in a specific tank or vessel. The simulation gives information on wetting intensity, pattern mesh width and cleaning jet velocity. This information is used to determine the best location of the tank cleaning device and the correct combination of flow, time, and pressure to implement.

A TRAX demo containing different cleaning simulations covering a variety of applications can be used as a reference and documentation for tank cleaning applications. The TRAX demo is free and available upon request.

Wetting Intensity

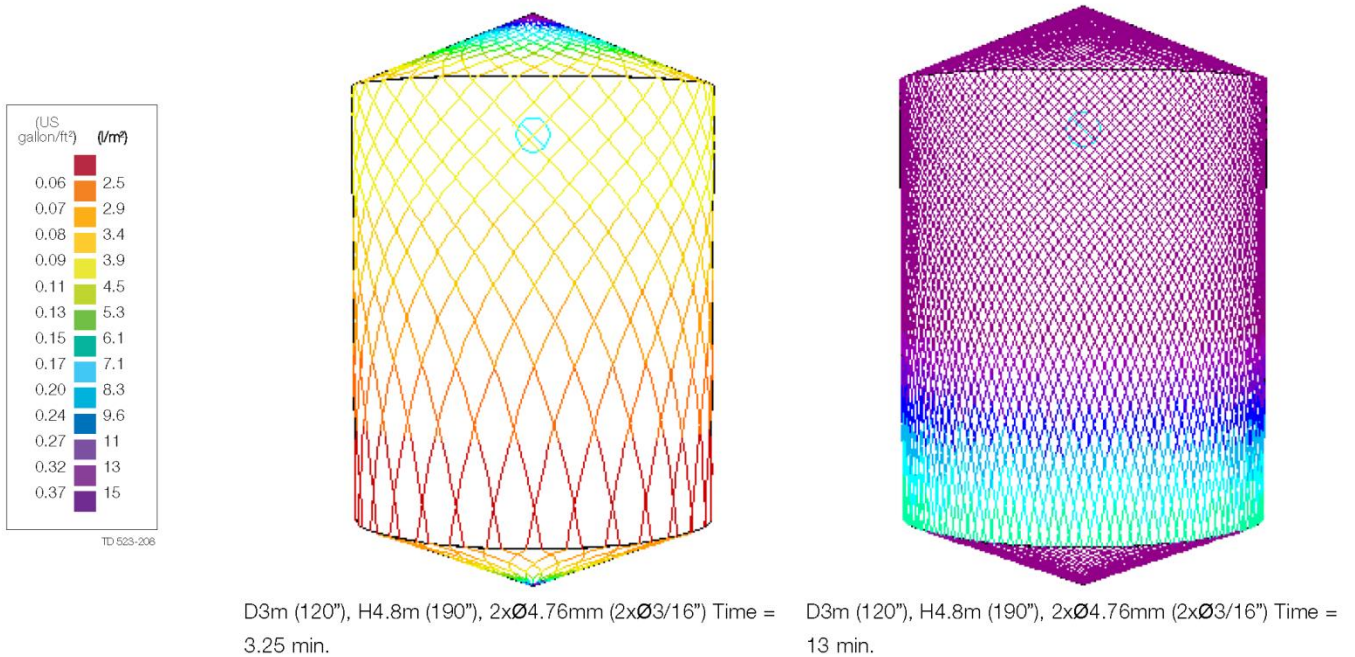

The Drawing shows Alfa Laval GJ A6 Tank Cleaning Machine

8.1 A6 View

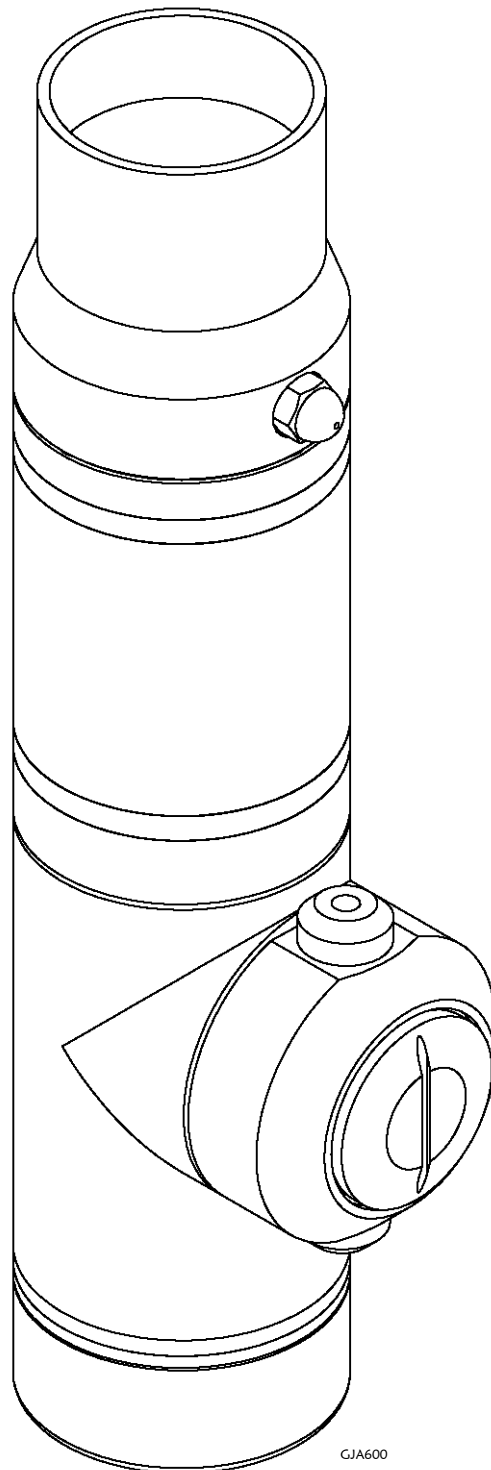

GJA600

8 Parts List and Service Kits

The Drawing shows Alfa Laval GJ A6 Tank Cleaning Machine

8.2 Assembly Drawings – 1 & 2

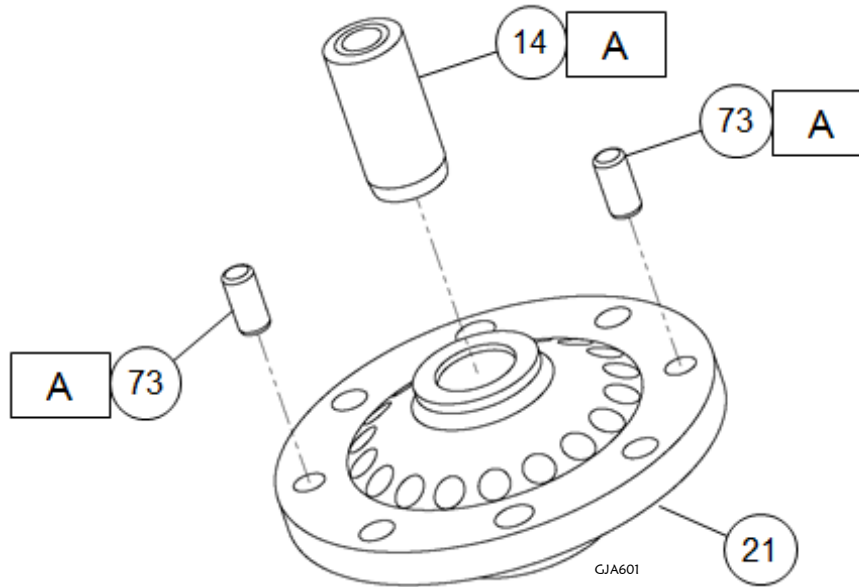

Drawing 1 – Gearhead Upper Flange

A: Press Fit

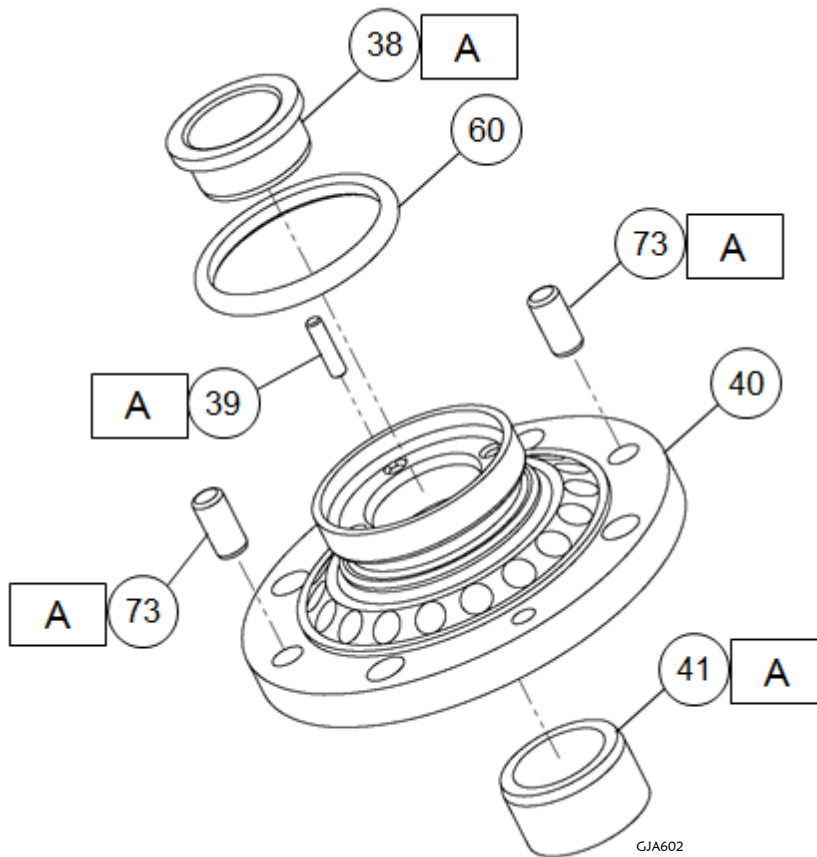

Drawing 2 – Gearhead Lower Flange

A: Press Fit

The Drawing shows Alfa Laval GJ A6 Tank Cleaning Machine

8.3 Assembly Drawings – 3, 4, 5 & 6

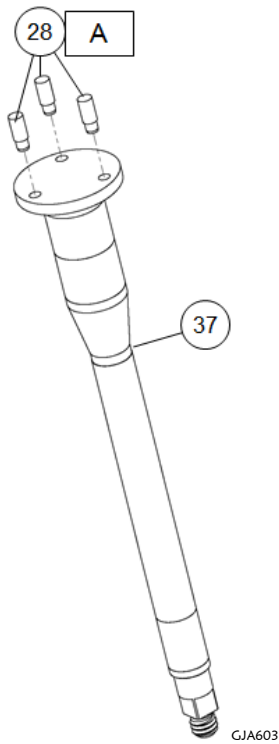

Drawing 3 – Output Shaft

A: Press Fit

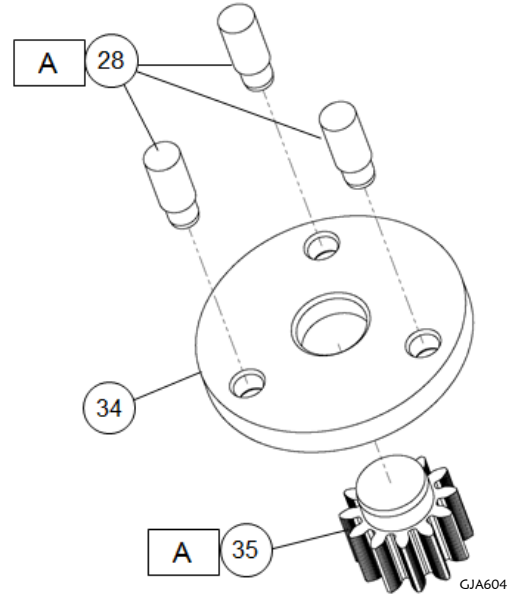

Drawing 4 – Planetary Gear Carrier

A: Press Fit

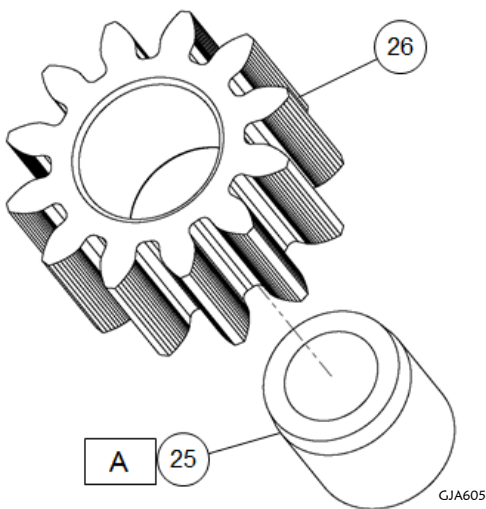

Drawing 5 – Planetary Gear

A: Press Fit

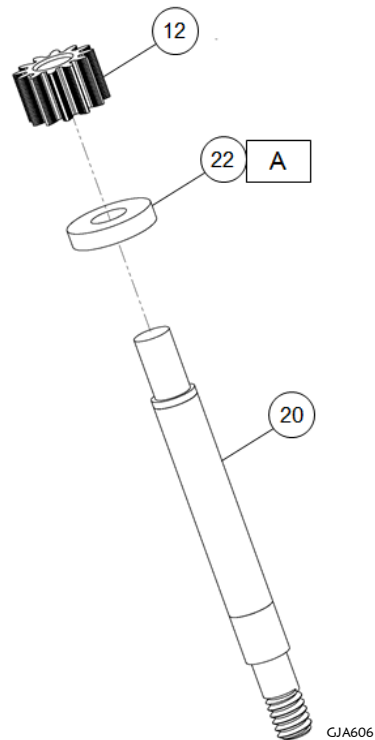

Drawing 6 – Input Shaft

A: Press Fit

Note: (12) gear must be completely perpendicular to the (20) shaft or it will not press on correctly and damage the (12) gear or the (20) shaft.

8 Parts List and Service Kits

The Drawing shows Alfa Laval GJ A6 Tank Cleaning Machine

8.4 Assembly Drawings – 7 & 8

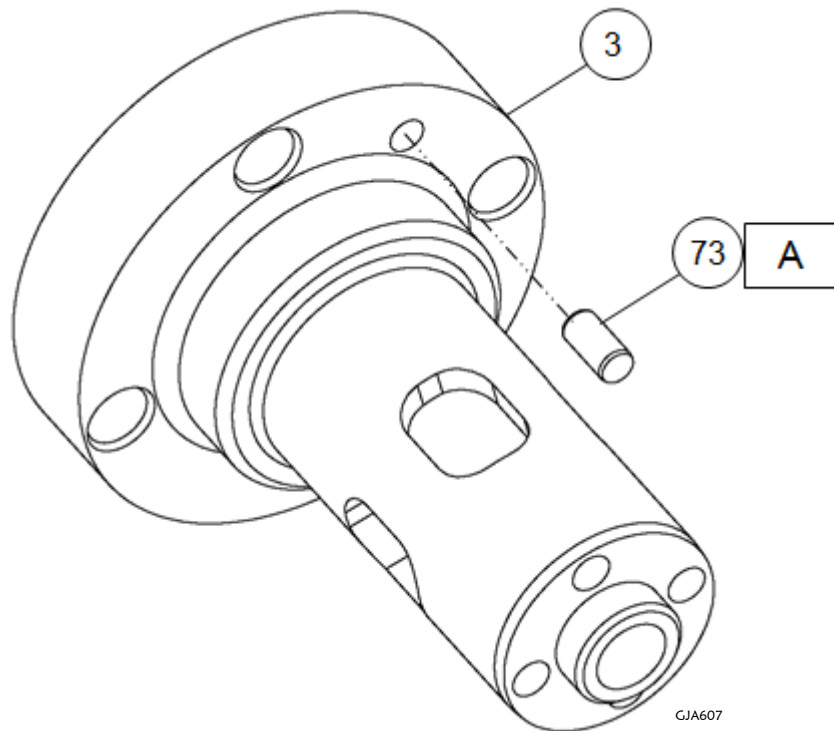

Drawing 7 - Stem

A: Press Fit

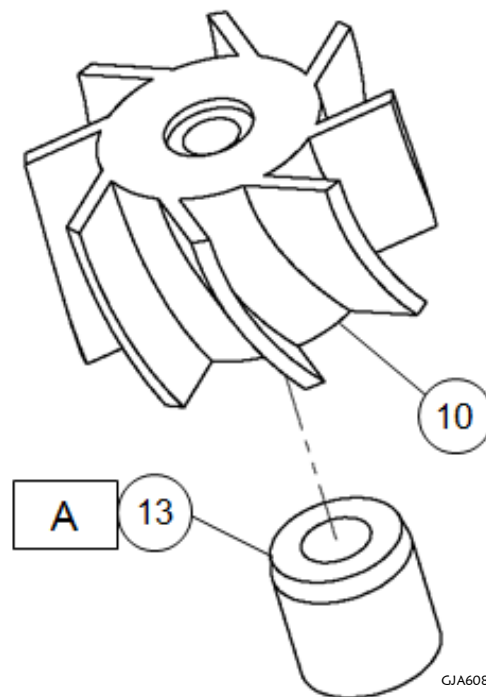

Drawing 8 - Rotor

A: Press Fit

The Drawing shows Alfa Laval GJ A6 Tank Cleaning Machine

8.5 Assembly Drawings – 9 & 10

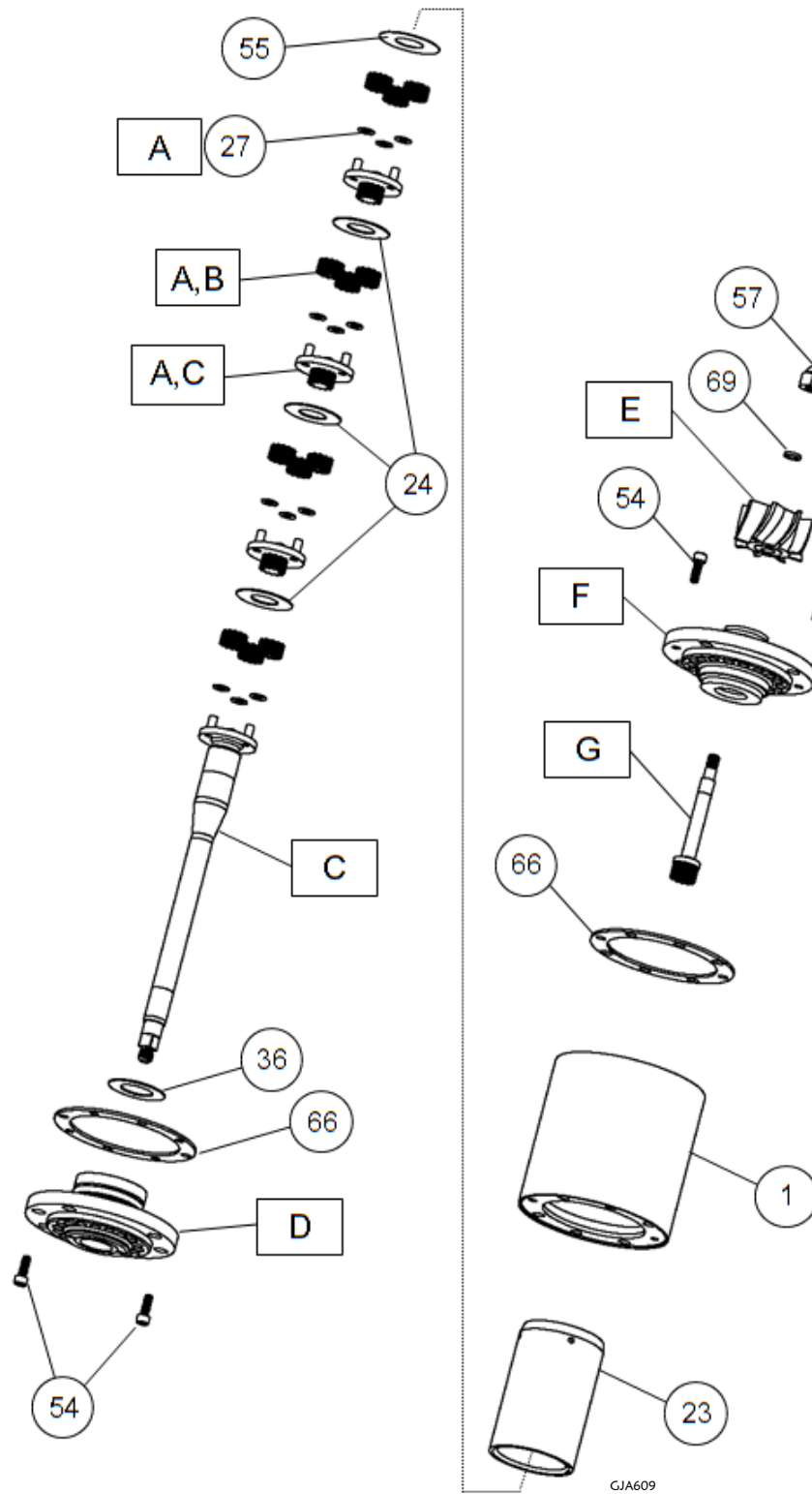

Drawing 9 – Planetary Gear Train

- A: Typical
- B: Drawing 5
- C: Drawing 4
- D: Drawing 2

- E: Drawing 8
- F: Drawing 1
- G: Drawing 6

8 Parts List and Service Kits

The Drawing shows Alfa Laval GJ A6 Tank Cleaning Machine

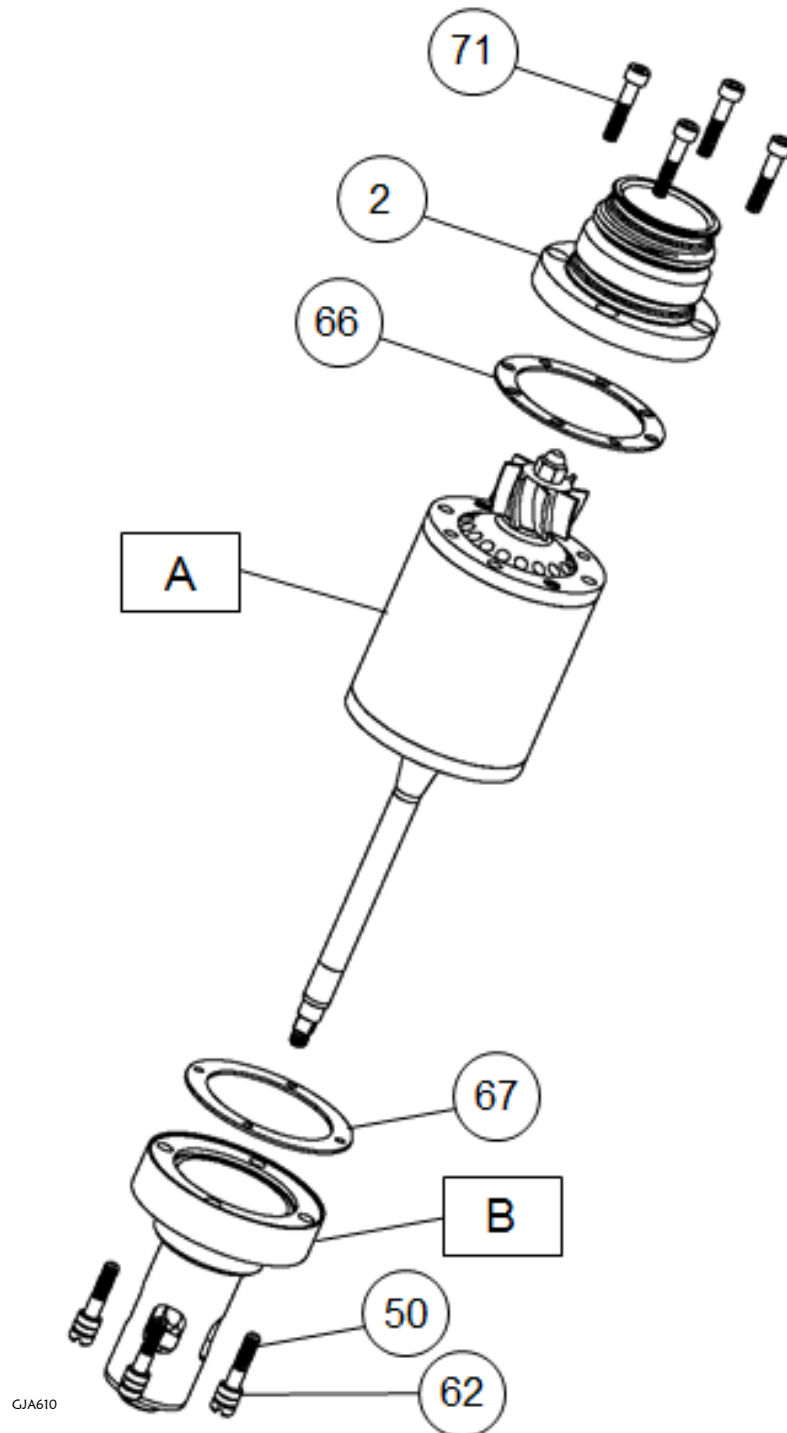

Drawing 10 – Installing Stem and Cap

A: Drawing 9

B: Drawing 7

The Drawing shows Alfa Laval GJ A6 Tank Cleaning Machine

8.6 Assembly Drawings – 11, 12, 13 & 14

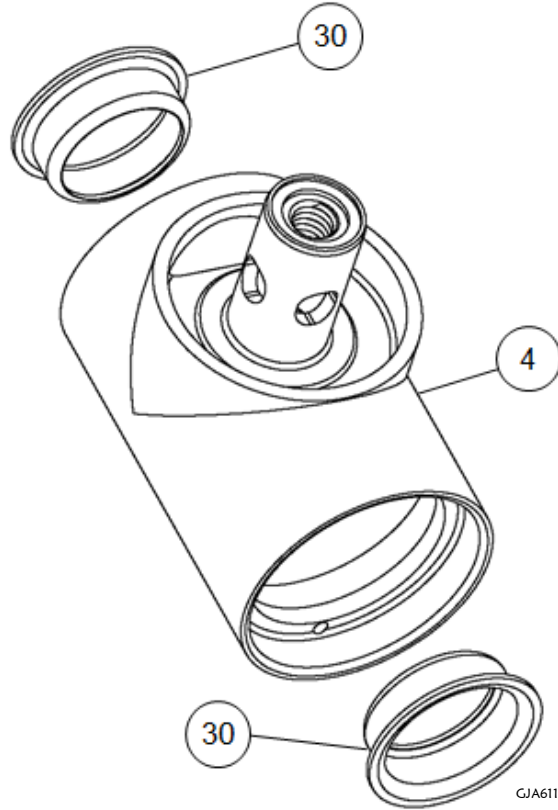

Drawing 11 – Tee Housing

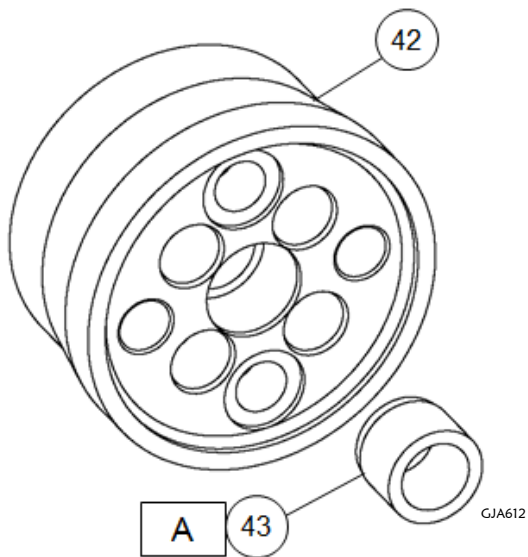

Drawing 12 – Idler Shaft Base

A: Press Fit

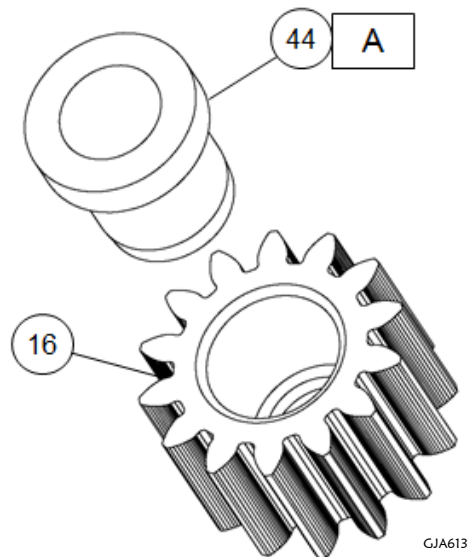

Drawing 13 – Idler Gear

A: Press Fit

8 Parts List and Service Kits

The Drawing shows Alfa Laval GJ A6 Tank Cleaning Machine

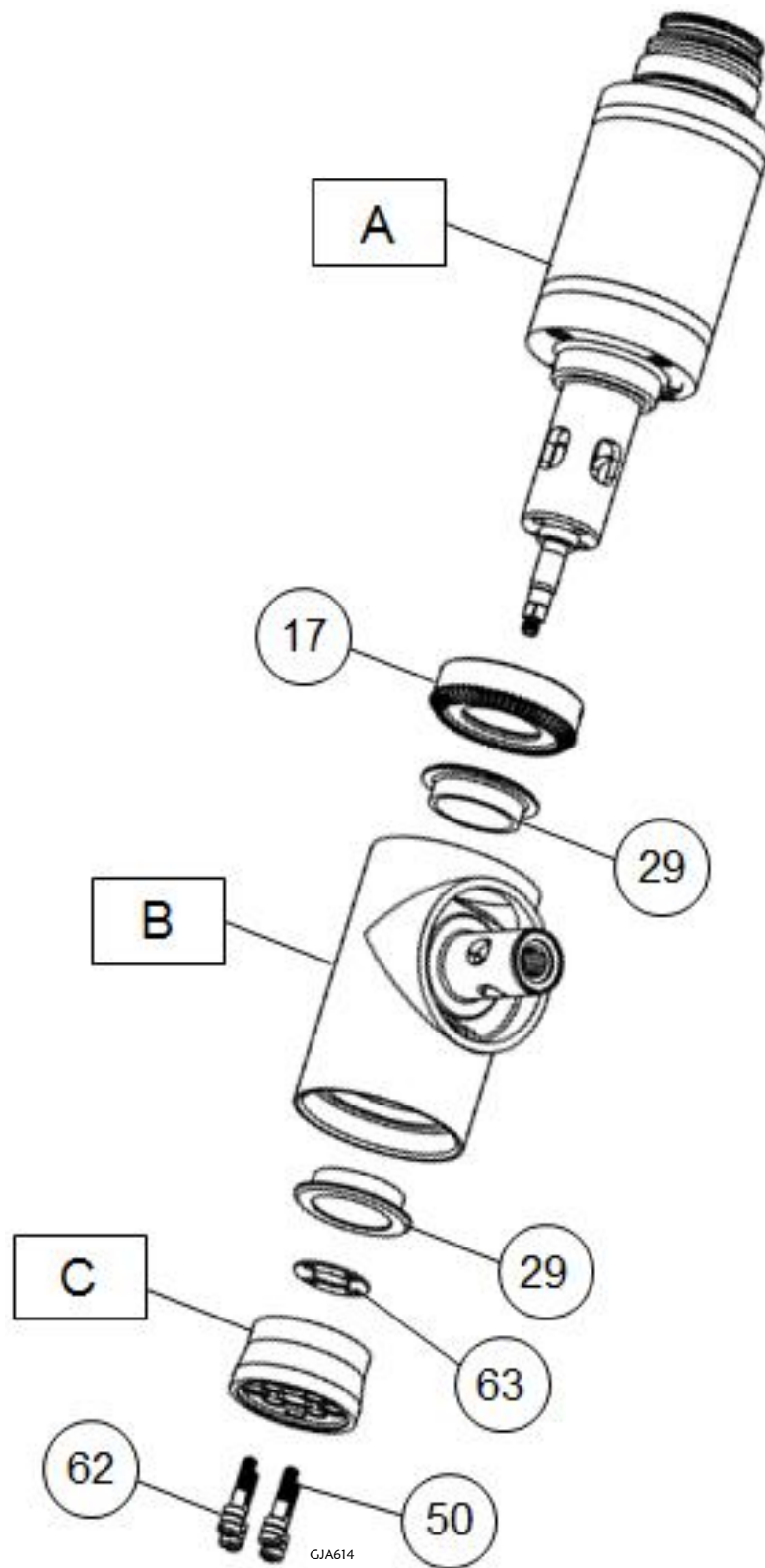

Drawing 14 – Body

A: Drawing 10

B: Drawing 11

C: Drawing 12

The Drawing shows Alfa Laval GJ A6 Tank Cleaning Machine

8.7 Assembly Drawings – 15 & 16

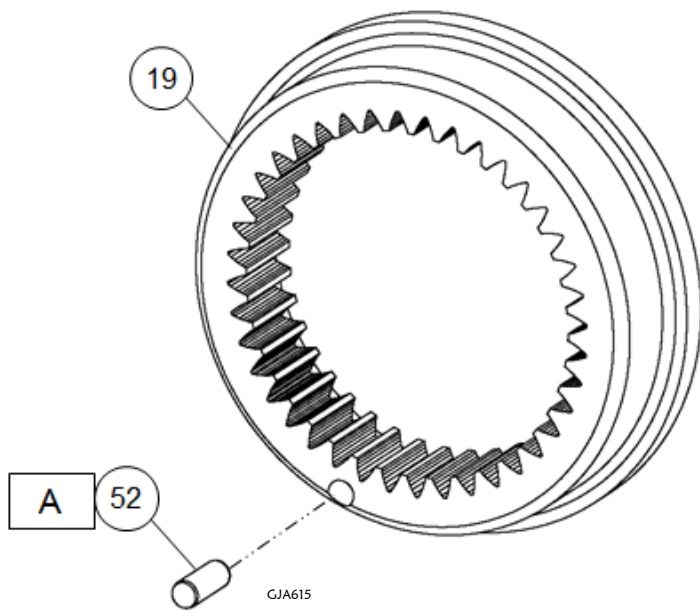

Drawing 15 – Ring Gear

A: Press Fit

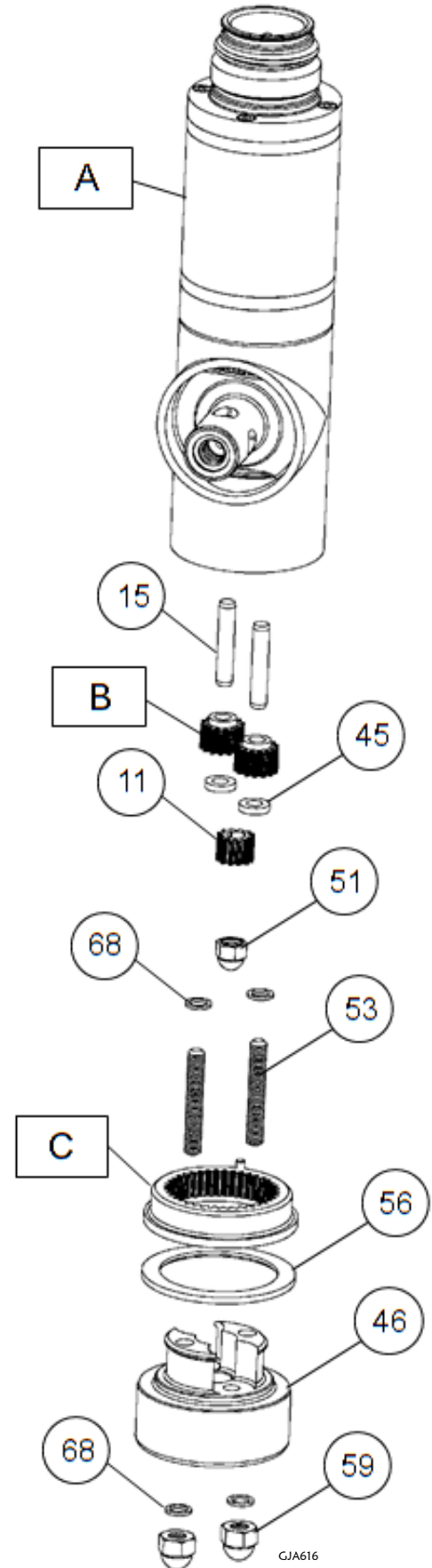

Drawing 16 – Installing Idler Gears and Base

A: Drawing 14

B: Drawing 13

C: Drawing 15

8 Parts List and Service Kits

The Drawing shows Alfa Laval GJ A6 Tank Cleaning Machine

8.8 Assembly Drawings – 17 & 18

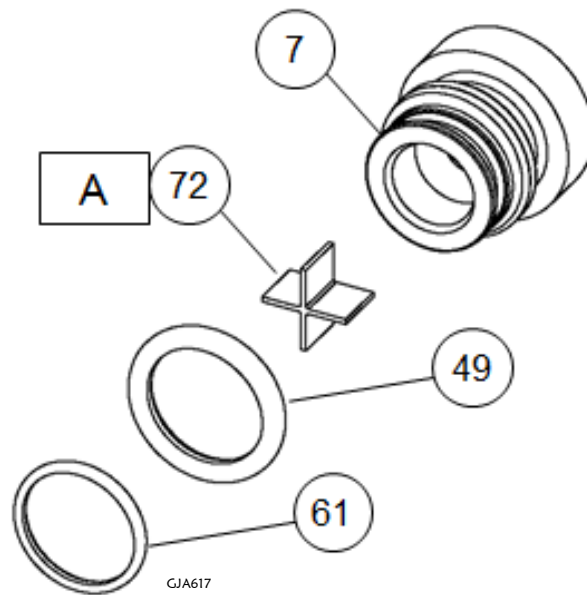

Drawing 17 – Nozzle

A: Part will protrude when installed. Press until part bottoms.

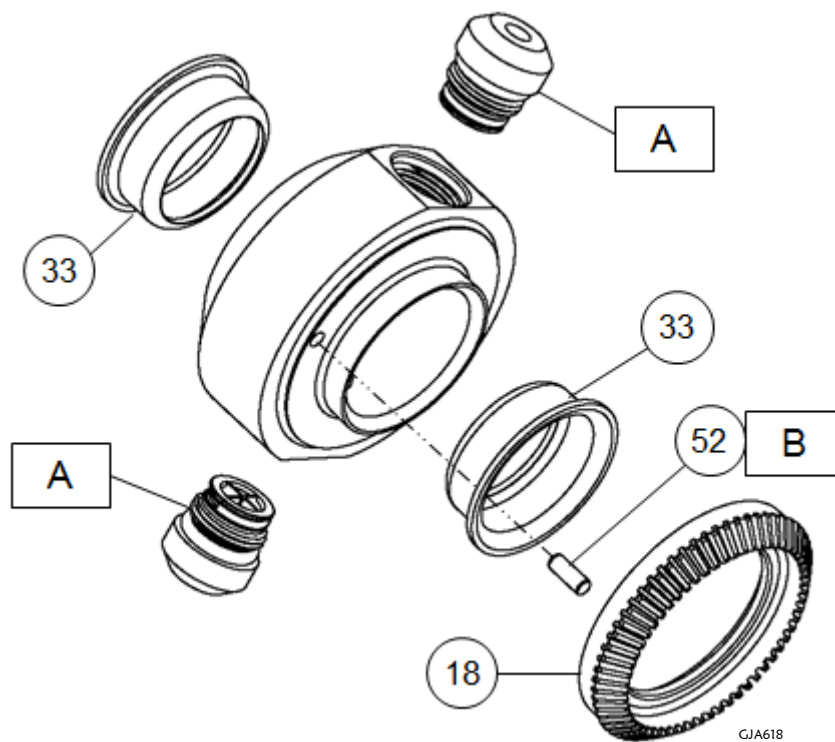

Drawing 18 – Nozzle Housing

A: Drawing 17

B: Press Fit

The Drawing shows Alfa Laval GJ A6 Tank Cleaning Machine

8.9 Assembly Drawing - 19

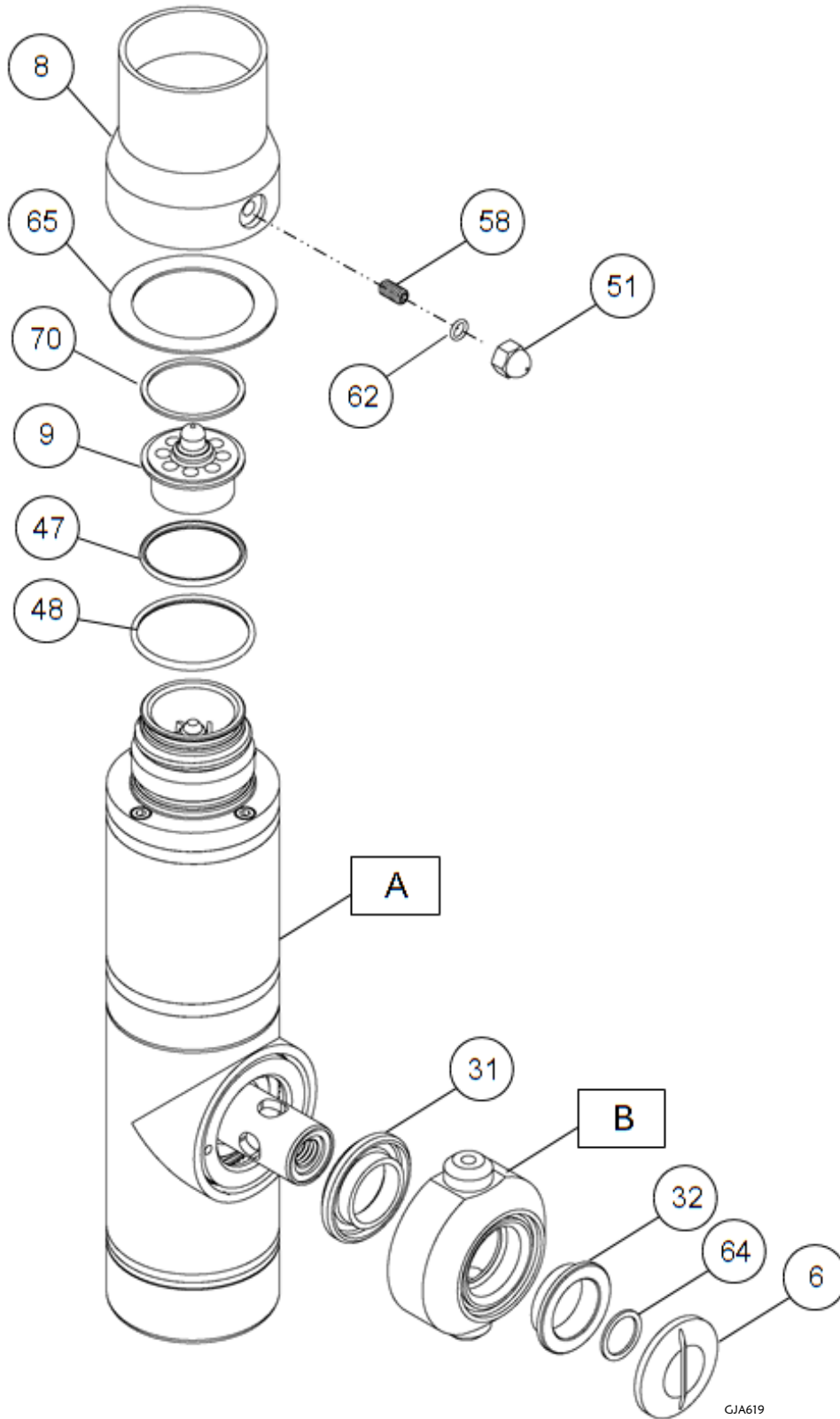

Drawing 19 – Final Assembly

A: Drawing 15

B: Drawing 18

8 Parts List and Service Kits

8.10 Parts List

Pos.	AL No.	Gamajet No.	Description	No.
1	9614620002	6-101-3-A	Upper Stem	1
2	9614620202	6-102-3-A	Cap	1
3	9614620302	6-103-3-A	Stem	1
4	9614620402	6-104-3-A	Tee Housing	1
5.1	9614620502	6-105-D-3-A	Dual Nozzle Housing	1
5.2	9614620602	6-105-T-3-A	Triple Nozzle Housing	1
6	9614620701	6-106	Nameplate	1
7.1	9614620901	6-107-ASE.125	A6 Nozzle Assembly - EPDM - 0.125"	2,3
7.2	9614620902	6-107-ASE.150	A6 Nozzle Assembly - EPDM - 0.150"	2,3
7.3	9614620903	6-107-ASE.165	A6 Nozzle Assembly - EPDM - 0.165"	2,3
7.4	9614620904	6-107-ASE.187	A6 Nozzle Assembly - EPDM - 0.187"	2,3
7.5	9614620905	6-107-ASE.225	A6 Nozzle Assembly - EPDM - 0.225"	2,3
7.6	9614621001	6-107-ASV.125	A6 Nozzle Assembly - Viton - 0.125"	2,3
7.7	9614621002	6-107-ASV.150	A6 Nozzle Assembly - Viton - 0.150"	2,3
7.8	9614621003	6-107-ASV.165	A6 Nozzle Assembly - Viton - 0.165"	2,3
7.9	9614621004	6-107-ASV.187	A6 Nozzle Assembly - Viton - 0.187"	2,3
7.10	9614621005	6-107-ASV.225	A6 Nozzle Assembly - Viton - 0.225"	2,3
7.11	9614621101	6-107-ASK.125	A6 Nozzle Assembly - Kalrez - 0.125"	2,3
7.12	9614621102	6-107-ASK.150	A6 Nozzle Assembly - Kalrez - 0.150"	2,3
7.13	9614621103	6-107-ASK.165	A6 Nozzle Assembly - Kalrez - 0.165"	2,3
7.14	9614621104	6-107-ASK.187	A6 Nozzle Assembly - Kalrez - 0.187"	2,3
7.15	9614621105	6-107-ASK.225	A6 Nozzle Assembly - Kalrez - 0.225"	2,3
8.1	9614621202	6-108-R	Collar	1
8.2	9614621203	6-108-S	Collar	1
9.1	9614621304	6-109-STD	Stator – Standard	1
9.2	9614621302	6-109-LV	Stator – Low Volume	1
9.3	9614621303	6-109-MV	Stator – Medium Volume	1
9.4	9614621301	6-109-HV	Stator – High Volume	1
10	9614621401	6-110	Rotor	1
11	9614621501	6-111	Output Pinion	1
12	9614621601	6-112	Input Pinion	1
13	9614621701	6-113	Rotor Shaft Carbide Bearing	1
14.1	9614621801	6-114	Long Rotor Shaft Carbide Bearing	1
14.2	9614621802	6-114-S	Silicon Rotor Shaft Carbide Bearing	2
15	9614622001	6-115-3-A	Idler Shaft	2
16	9614622101	6-116	Idler Gear	2
17	9614622301	6-117-3-A	Tee Housing Bevel Gear	1
18	9614622401	6-118	Nozzle Housing Bevel Gear	1
19	9614622601	6-120-3-A	Ring Gear	1
20	9614622801	6-122	Rotor Shaft	1
21	9614623101	6-123-3-A	Gearhead Upper Flange	1
22	9614623201	6-124	Input Pinion Thrust Washer	1
23	9614623301	6-125	Planetary Ring Gear	1
24	9614623401	6-126	Planetary Gearhead Large Washer	3
25	9614623601	6-127-3-A	Planet Gear Bushing	12
26	9614623701	6-128	Planet Gear	12
27	9614623801	6-129	Planet Gear Washer	12
28	9614623901	6-130	Planet Gear Idler Shaft	12
29	9614624101	6-131-3-A	Tee Housing Bearing	2
30	9614624201	6-132	Tee Housing Cup	2
31	9614624401	6-133-3-A-I	Nozzle Housing Bearing, Inner	1
32	9614624501	6-133-3-A-O	Nozzle Housing Bearing, Outer	1
33	9614624601	6-134	Nozzle Housing Cup	2
34	9614624901	6-137	Planet Gear Carrier	3
35	9614625001	6-138	Planet Gear Carrier Pinion	3
36	9614625101	6-140	Planetary Output Shaft Washer	1
37	9614625201	6-141	Output Shaft	1
38	9614625501	6-142-3-A	Planetary Output Shaft Upper Bushing	1
39	9614625601	6-143	Planetary Gearhead Pin	1
40	9614625801	6-144-3-A	Planetary Output Shaft Bearing Housing	1

8 Parts List and Service Kits

Pos.	AL No.	Gamajet No.	Description	No.
41.1	9614625901	6-145	Planetary Output Shaft Carbide Bearing	1
41.2	9614625902	6-145-S	Silicon Planetary Output Shaft Carbide Bearing	1
42	9614626101	6-146-3-A	Idler Shaft Base	1
43.1	9614626201	6-147	Output Shaft Lower Carbide Bearing	1
43.2	9614626202	6-147-S	Output Shaft Lower Carbide Bearing- Silicone	1
44	9614626401	6-148-3-A	Idler Gear Bushing	2
45	9614626601	6-149-3-A	Idler Shaft Bushing	2
46	9614626801	6-150-3-A	Base	1
47.1	9614626901	6-153-E	Upper Cap O-ring – EPDM	1
47.2	9614626902	6-153-V	Upper Cap O-ring – Viton	1
47.3	9614626903	6-153-K	Upper Cap O-ring – Kalrez	1
48.1	9614627001	6-154-E	Lower Cap O-ring - EPDM	1
48.2	9614627002	6-154-V	Lower Cap O-ring – Viton	1
48.3	9614627003	6-154-K	Lower Cap O-ring – Kalrez	1
49.1	9614627101	6-155-3-A-E	Nozzle Outer O-ring – EPDM	2,3
49.2	9614627104	6-155-3-A-V	Nozzle Outer O-ring – Viton	2,3
49.3	9614627103	6-155-3-A-K	Nozzle Outer O-ring – Kalrez	2,3
50	9614627301	6-157-3-A	Idler Shaft Base/Stem Screw	8
51	9614627701	6-165-3-A	Output Pinion/Collar Nut	2
52	9614627801	6-166	Nozzle Housing/Ring Gear Drive Pin	2
53	9614628001	6-167-3-A	Base Screw	2
54	9614628101	6-168	Planetary Gearhead Screw	4
55	9614628201	6-170	Planetary Gearhead Top Washer	1
56	9614628301	6-171-3-A	Ring Gear Spacer	1
57	9614628401	6-172	Rotor Nut	1
58	9614628501	6-173	Collar Set Screw	1
59	9614628601	6-174	Base Nut	2
60	9614628701	6-175	Gearhead O-ring – EPDM	1
61	9614628801	6-176-E	Nozzle Inner O-ring – EPDM	2,3
62	9614628901	6-177-E	Screw O-ring – EPDM	10
63.1	9614629101	6-181-E	Stem-Idler Shaft Gasket – EPDM	1
63.2	9614629102	6-181-K	Stem-Idler Shaft Gasket – Kalrez	1
63.3	9614629103	6-181-V	Stem-Idler Shaft Gasket – Viton	1
64.1	9614629201	6-182-E	Tee Housing Nose Gasket – EPDM	1
64.2	9614629202	6-182-K	Tee Housing Nose Gasket – Kalrez	1
64.3	9614629203	6-182-V	Tee Housing Nose Gasket – Viton	1
65.1	9614629301	6-185-E	Collar Gasket- EPDM	1
65.2	9614629302	6-185-K	Collar Gasket – Kalrez	1
65.3	9614629303	6-185-V	Collar Gasket – Viton	1
66.1	9614629401	6-186-E	Body Gasket – EPDM	3
66.2	9614629402	6-186-K	Body Gasket – Kalrez	3
66.3	9614629403	6-186-V	Body Gasket – Viton	3
67.1	9614629501	6-187-E	Stem Large Gasket – EPDM	1
67.2	9614629502	6-187-K	Stem Large Gasket – Kalrez	1
67.3	9614629503	6-187-V	Stem Large Gasket – Viton	1
68.1	9614629601	6-188-E	Base Screw Gasket – EPDM	4
68.2	9614629602	6-188-K	Base Screw Gasket – Kalrez	4
68.3	9614629603	6-188-V	Base Screw Gasket – Viton	4
69.1	9614629701	6-189-E	Rotor Gasket – EPDM	1
69.2	9614629702	6-189-K	Rotor Gasket – Kalrez	1
69.3	9614629703	6-189-V	Rotor Gasket – Viton	1
70.1	9614629801	6-190-E	Stator Gasket - EPDM	1
70.2	9614629802	6-190-K	Stator Gasket – Kalrez	1
70.3	9614629803	6-190-V	Stator Gasket - Viton	4
71	9614685501	7-740	Cap Screw	4
72	9614678701	8-549	Nozzle Stream Straightener	2,3
73	9614611101	E-866	Cap and Stem Pin	5

8 Parts List and Service Kits

8.11 Minor Service Kit

Article no: 9614629901 63AEPDMKIT ALFA LAVAL GJ A6 KIT - EPDM				
Pos. No.	Part No.	Gamajet Part No.	Description	No.
25	9614623601	61273A	PLANETARY GEARHEAD BUSHING	12 pcs.
29	9614624101	61313A	TEE HOUSING BEARING-3A	2 pcs.
31	9614624401	61333AI	NZL HOUSING BEARING-3A-INNER	1 pcs.
32	9614624501	61333AO	NOZZLE HOUSING BEARING-3A	1 pcs.
38	9614625501	61423A	PL OUTPUT SHAFT UPR BSG-3A	1 pcs.
44	9614626401	61483A	IDLER GEAR BUSHING-3A	2 pcs.
45	9614626601	61493A	IDLER SHAFT BUSHING-3A	2 pcs.
49	9614627101	61553AE	NOZZLE O-RING - EPDM-3A	3 pcs.
56	9614628301	61713A	RING GEAR SPACER - 3A	1 pcs.
60	9614628701	6175	GEARHEAD O-RING - EPDM	1 pcs.
61	9614628801	6176	NOZZLE INNER O-RING - EPDM	3 pcs.
62	9614628901	6177	SCREW O-RING - EPDM	10 pcs.
63	9614629101	6181E	GJ A6 STEM GASKET - EPDM	1 pcs.
64	9614629201	6182E	GJ A6 NOSE GASKET - EPDM	1 pcs.
65	9614629301	6185E	GJ A6 COLLAR GASKET-EPDM	1 pcs.
66	9614629401	6186E	GJ A6 LOWER BODY GASKET-EPDM	3 pcs.
67	9614629501	6187E	GJ A6 LARGE STEM GASKET-EPDM	1 pcs.
68	9614629601	6188E	GJ A6 BASE SCREW GASKET-EPDM	4 pcs.
69	9614629701	6189E	GJ A6 ROTOR GASKET-EPDM	1 pcs.
70	9614629801	6190E	GJ VI STATOR GASKET-EPDM	1 pcs.

Article no: 9614629903 63AVITONKIT ALFA LAVAL GJ A6 KIT - VITON				
Pos. No.	Part No.	Gamajet Part No.	Description	No.
25	9614623601	61273A	PLANETARY GEARHEAD BUSHING	12 pcs.
29	9614624101	61313A	TEE HOUSING BEARING-3A	2 pcs.
31	9614624401	61333AI	NZL HOUSING BEARING-3A-INNER	1 pcs.
32	9614624501	61333AO	NOZZLE HOUSING BEARING-3A	1 pcs.
38	9614625501	61423A	PL OUTPUT SHAFT UPR BSG-3A	1 pcs.
44	9614626401	61483A	IDLER GEAR BUSHING-3A	2 pcs.
45	9614626601	61493A	IDLER SHAFT BUSHING-3A	2 pcs.
49	9614627104	6155V	NOZZLE O-RING - VITON	3 pcs.
56	9614628301	61713A	RING GEAR SPACER - 3A	1 pcs.
60	9614661401	381160	638-V HOUSING O-RING UPPERII	1 pcs.
61	9614686703	7753V	GJ VII INPUT SHAFT LOWER BEARI	3 pcs.
62	9614677901	8541	GJ V GB NS / VIII RS O-RING	10 pcs.
63	9614629103	6181V	GJ A6 STEM GASKET - VITON	1 pcs.
64	9614629203	6182V	GJ A6 NOSE GASKET - VITON	1 pcs.
65	9614629303	6185V	GJ A6 COLLAR GASKET-VITON	1 pcs.
66	9614629403	6186V	GJ A6 LOWER BODY GASKET-VITON	3 pcs.
67	9614629503	6187V	GJ A6 LARGE STEM GASKET-VITON	1 pcs.
68	9614629603	6188V	GJ A6 BASE SCREW GASKET-VITON	4 pcs.
69	9614629703	6189V	GJ A6 ROTOR GASKET-VITON	1 pcs.
70	9614629803	6190V	GJ VI STATOR GASKET-VITON	1 pcs.

8 Parts List and Service Kits

Article no: 9614629905 63AKALREZKIT ALFA LAVAL GJ A6 KIT - KALREZ				
Pos. No.	Part No.	Gamajet Part No.	Description	No.
25	9614623601	61273A	PLANETARY GEARHEAD BUSHING	12 pcs.
29	9614624101	61313A	TEE HOUSING BEARING-3A	2 pcs.
31	9614624401	61333AI	NZL HOUSING BEARING-3A-INNER	1 pcs.
32	9614624501	61333AO	NOZZLE HOUSING BEARING-3A	1 pcs.
38	9614625501	61423A	PL OUTPUT SHAFT UPR BSG-3A	1 pcs.
44	9614626401	61483A	IDLER GEAR BUSHING-3A	2 pcs.
45	9614626601	61493A	IDLER SHAFT BUSHING-3A	2 pcs.
49	9614627103	6155K	NOZZLE O-RING - KALREZ	3 pcs.
56	9614628301	61713A	RING GEAR SPACER - 3A	1 pcs.
60	9614661403	381180	638-Z HOUSING O-RING UPPERII	1 pcs.
61	9614686702	7753K	GJ VII INPUT SHAFT LOWER BEARI	3 pcs.
62	9614677902	8541EP	GJ V GB NS / VIII RS O-RING	10 pcs.
63	9614629102	6181K	GJ A6 STEM GASKET - KALREZ	1 pcs.
64	9614629202	6182K	GJ A6 NOSE GASKET - KALREZ	1 pcs.
65	9614629302	6185K	GJ A6 COLLAR GASKET-KALREZ	1 pcs.
66	9614629402	6186K	GJ A6 LOWER BODY GASKET-KALREZ	3 pcs.
67	9614629502	6187K	GJ A6 LARGE STEM GASKET-KALREZ	1 pcs.
68	9614629602	6188K	GJ A6 BASE SCREW GASKET-KALREZ	4 pcs.
69	9614629702	6189K	GJ A6 ROTOR GASKET-KALREZ	1 pcs.
70	9614629802	6190K	GJ VI STATOR GASKET-KALREZ	1 pcs.

Article no: 9614629902 63AHPEPDMKIT ALFA LAVAL GJ A6 HP KIT - EPDM				
Pos. No.	Part No.	Gamajet Part No.	Description	No.
25	9614623601	61273A	PLANETARY GEARHEAD BUSHING	12 pcs.
29	9614624101	61313A	TEE HOUSING BEARING-3A	2 pcs.
31	9614624401	61333AI	NZL HOUSING BEARING-3A-INNER	1 pcs.
32	9614624501	61333AO	NOZZLE HOUSING BEARING-3A	1 pcs.
38	9614625501	61423A	PL OUTPUT SHAFT UPR BSG-3A	1 pcs.
44	9614626401	61483A	IDLER GEAR BUSHING-3A	2 pcs.
45	9614626601	61493A	IDLER SHAFT BUSHING-3A	2 pcs.
49	9614627101	61553AE	NOZZLE O-RING - EPDM-3A	3 pcs.
56	9614628301	61713A	RING GEAR SPACER - 3A	1 pcs.
60	9614628701	6175	GEARHEAD O-RING - EPDM	1 pcs.
61	9614628801	6176	NOZZLE INNER O-RING - EPDM	3 pcs.
62	9614628901	6177	SCREW O-RING - EPDM	10 pcs.
63	9614629101	6181E	GJ A6 STEM GASKET - EPDM	1 pcs.
64	9614629201	6182E	GJ A6 NOSE GASKET - EPDM	1 pcs.
65	9614629301	6185E	GJ A6 COLLAR GASKET-EPDM	1 pcs.
66	9614629401	6186E	GJ A6 LOWER BODY GASKET-EPDM	3 pcs.
67	9614629501	6187E	GJ A6 LARGE STEM GASKET-EPDM	1 pcs.
68	9614629601	6188E	GJ A6 BASE SCREW GASKET-EPDM	4 pcs.
69	9614629701	6189E	GJ A6 ROTOR GASKET-EPDM	1 pcs.
70	9614629801	6190E	GJ VI STATOR GASKET-EPDM	1 pcs.
74	9614624701	6135	TEE HOUSING SEAL	2 pcs.
75	9614624801	6136	NOZZLE HOUSING SEAL	2 pcs.

8 Parts List and Service Kits

Article no: 9614629906 63AHPKALREZKIT ALFA LAVAL GJ A6 HP KIT - KALREZ				
Pos. No.	Part No.	Gamajet Part No.	Description	No.
25	9614623601	61273A	PLANETARY GEARHEAD BUSHING	12 pcs.
29	9614624101	61313A	TEE HOUSING BEARING-3A	2 pcs.
31	9614624401	61333AI	NZL HOUSING BEARING-3A-INNER	1 pcs.
32	9614624501	61333AO	NOZZLE HOUSING BEARING-3A	1 pcs.
74	9614624701	6135	TEE HOUSING SEAL	2 pcs.
75	9614624801	6136	NOZZLE HOUSING SEAL	2 pcs.
38	9614625501	61423A	PL OUTPUT SHAFT UPR BSG-3A	1 pcs.
44	9614626401	61483A	IDLER GEAR BUSHING-3A	2 pcs.
45	9614626601	61493A	IDLER SHAFT BUSHING-3A	2 pcs.
49	9614627103	6155K	NOZZLE O-RING - KALREZ	3 pcs.
56	9614628301	61713A	RING GEAR SPACER - 3A	1 pcs.
60	9614661403	381180	638-Z HOUSING O-RING UPPERII	1 pcs.
61	9614686702	7753K	GJ VII INPUT SHAFT LOWER BEARI	3 pcs.
62	9614677902	8541EP	GJ V GB NS / VIII RS O-RING	10 pcs.
63	9614629102	6181K	GJ A6 STEM GASKET - KALREZ	1 pcs.
64	9614629202	6182K	GJ A6 NOSE GASKET - KALREZ	1 pcs.
65	9614629302	6185K	GJ A6 COLLAR GASKET-KALREZ	1 pcs.
66	9614629402	6186K	GJ A6 LOWER BODY GASKET-KALREZ	3 pcs.
67	9614629502	6187K	GJ A6 LARGE STEM GASKET-KALREZ	1 pcs.
68	9614629602	6188K	GJ A6 BASE SCREW GASKET-KALREZ	4 pcs.
69	9614629702	6189K	GJ A6 ROTOR GASKET-KALREZ	1 pcs.
70	9614629802	6190K	GJ VI STATOR GASKET-KALREZ	1 pcs.

8.9 Major Service Kit

Article no: 9614630001 63AMAJEPDMKIT ALFA LAVAL GJ A6 MAJOR KIT - EPDM				
Pos. No.	Part No.	Gamajet Part No.	Description	No.
25	9614623601	61273A	PLANETARY GEARHEAD BUSHING	12 pcs.
29	9614624101	61313A	TEE HOUSING BEARING-3A	2 pcs.
31	9614624401	61333AI	NZL HOUSING BEARING-3A-INNER	1 pcs.
32	9614624501	61333AO	NOZZLE HOUSING BEARING-3A	1 pcs.
38	9614625501	61423A	PL OUTPUT SHAFT UPR BSG-3A	1 pcs.
44	9614626401	61483A	IDLER GEAR BUSHING-3A	2 pcs.
45	9614626601	61493A	IDLER SHAFT BUSHING-3A	2 pcs.
49	9614627101	61553AE	NOZZLE O-RING - EPDM-3A	3 pcs.
56	9614628301	61713A	RING GEAR SPACER - 3A	1 pcs.
60	9614628701	6175	GEARHEAD O-RING - EPDM	1 pcs.
61	9614628801	6176	NOZZLE INNER O-RING - EPDM	3 pcs.
62	9614628901	6177	SCREW O-RING - EPDM	10 pcs.
63	9614629101	6181E	GJ A6 STEM GASKET - EPDM	1 pcs.
64	9614629201	6182E	GJ A6 NOSE GASKET - EPDM	1 pcs.
65	9614629301	6185E	GJ A6 COLLAR GASKET-EPDM	1 pcs.
66	9614629401	6186E	GJ A6 LOWER BODY GASKET-EPDM	3 pcs.
67	9614629501	6187E	GJ A6 LARGE STEM GASKET-EPDM	1 pcs.
68	9614629601	6188E	GJ A6 BASE SCREW GASKET-EPDM	4 pcs.
69	9614629701	6189E	GJ A6 ROTOR GASKET-EPDM	1 pcs.
70	9614629801	6190E	GJ VI STATOR GASKET-EPDM	1 pcs.
11	9614621501	6111	OUTPUT PINION	1 pcs.
16	9614622101	6116	IDLER GEAR	2 pcs.
20	9614622901	6122AS	INPUT PINION ASSEMBLY	1 pcs.
24	9614623401	6126	PLANETARY GEARHEAD LG WASHER	3 pcs.
26	9614623701	6128	PLANETARY GEAR	12 pcs.
27	9614623801	6129	PLANETARY GEAR WASHER	12 pcs.
28	9614623901	6130	PLANETARY GEAR IDLER SHAFT	12 pcs.
30	9614624201	6132	TEE HOUSING CUP	2 pcs.
33	9614624601	6134	NOZZLE HOUSING CUP	2 pcs.
34	9614624901	6137	PLANETARY GEAR CARRIER	1 pcs.
35	9614625001	6138	PLANETARY GEAR CARRIER PINION	1 pcs.
36	9614625101	6140	PLANETARY OUTPUT SHAFT WASHER	1 pcs.
37	9614625201	6141	OUTPUT SHAFT	1 pcs.
54	9614628101	6168	PLANETARY HOUSING SCREW	4 pcs.
55	9614628201	6170	PLANETARY OUTPUT SHAFT WASHER	1 pcs.

8 Parts List and Service Kits

Article no: 9614630003 63AMAJVITONKIT ALFA LAVAL GJ A6 MAJOR KIT - VITON				
Pos. No.	Part No.	Gamajet Part No.	Description	No.
25	9614623601	61273A	PLANETARY GEARHEAD BUSHING	12 pcs.
29	9614624101	61313A	TEE HOUSING BEARING-3A	2 pcs.
31	9614624401	61333AI	NZL HOUSING BEARING-3A-INNER	1 pcs.
32	9614624501	61333AO	NOZZLE HOUSING BEARING-3A	1 pcs.
38	9614625501	61423A	PL OUTPUT SHAFT UPR BSG-3A	1 pcs.
44	9614626401	61483A	IDLER GEAR BUSHING-3A	2 pcs.
45	9614626601	61493A	IDLER SHAFT BUSHING-3A	2 pcs.
49	9614627104	6155V	NOZZLE O-RING - VITON	3 pcs.
56	9614628301	61713A	RING GEAR SPACER - 3A	1 pcs.
60	9614661401	381160	638-V HOUSING O-RING UPPERII	1 pcs.
61	9614686703	7753V	GJ VII INPUT SHAFT LOWER BEARI	3 pcs.
62	9614677901	8541	GJ V GB NS / VIII RS O-RING	10 pcs.
63	9614629103	6181V	GJ A6 STEM GASKET - VITON	1 pcs.
64	9614629203	6182V	GJ A6 NOSE GASKET - VITON	1 pcs.
65	9614629303	6185V	GJ A6 COLLAR GASKET-VITON	1 pcs.
66	9614629403	6186V	GJ A6 LOWER BODY GASKET-VITON	3 pcs.
67	9614629503	6187V	GJ A6 LARGE STEM GASKET-VITON	1 pcs.
68	9614629603	6188V	GJ A6 BASE SCREW GASKET-VITON	4 pcs.
69	9614629703	6189V	GJ A6 ROTOR GASKET-VITON	1 pcs.
70	9614629803	6190V	GJ VI STATOR GASKET-VITON	1 pcs.
11	9614621501	6111	OUTPUT PINION	1 pcs.
16	9614622101	6116	IDLER GEAR	2 pcs.
20	9614622901	6122AS	INPUT PINION ASSEMBLY	1 pcs.
24	9614623401	6126	PLANETARY GEARHEAD LG WASHER	3 pcs.
26	9614623701	6128	PLANETARY GEAR	12 pcs.
27	9614623801	6129	PLANETARY GEAR WASHER	12 pcs.
28	9614623901	6130	PLANETARY GEAR IDLER SHAFT	12 pcs.
30	9614624201	6132	TEE HOUSING CUP	2 pcs.
33	9614624601	6134	NOZZLE HOUSING CUP	2 pcs.
34	9614624901	6137	PLANETARY GEAR CARRIER	1 pcs.
35	9614625001	6138	PLANETARY GEAR CARRIER PINION	1 pcs.
36	9614625101	6140	PLANETARY OUTPUT SHAFT WASHER	1 pcs.
37	9614625201	6141	OUTPUT SHAFT	1 pcs.
54	9614628101	6168	PLANETARY HOUSING SCREW	4 pcs.
55	9614628201	6170	PLANETARY OUTPUT SHAFT WASHER	1 pcs.

8 Parts List and Service Kits

Article no: 9614630004 63AMAJKALREZKIT ALFA LAVAL GJ A6 MAJOR KIT - KALREZ				
Pos. No.	Part No.	Gamajet Part No.	Description	No.
25	9614623601	61273A	PLANETARY GEARHEAD BUSHING	12 pcs.
29	9614624101	61313A	TEE HOUSING BEARING-3A	2 pcs.
31	9614624401	61333AI	NZL HOUSING BEARING-3A-INNER	1 pcs.
32	9614624501	61333AO	NOZZLE HOUSING BEARING-3A	1 pcs.
38	9614625501	61423A	PL OUTPUT SHAFT UPR BSG-3A	1 pcs.
44	9614626401	61483A	IDLER GEAR BUSHING-3A	2 pcs.
45	9614626601	61493A	IDLER SHAFT BUSHING-3A	2 pcs.
49	9614627103	6155K	NOZZLE O-RING - KALREZ	3 pcs.
56	9614628301	61713A	RING GEAR SPACER - 3A	1 pcs.
60	9614661403	381180	638-Z HOUSING O-RING UPPERII	1 pcs.
61	9614686702	7753K	GJ VII INPUT SHAFT LOWER BEARI	3 pcs.
62	9614677902	8541EP	GJ V GB NS / VIII RS O-RING	10 pcs.
63	9614629102	6181K	GJ A6 STEM GASKET - KALREZ	1 pcs.
64	9614629202	6182K	GJ A6 NOSE GASKET - KALREZ	1 pcs.
65	9614629302	6185K	GJ A6 COLLAR GASKET-KALREZ	1 pcs.
66	9614629402	6186K	GJ A6 LOWER BODY GASKET-KALREZ	3 pcs.
67	9614629502	6187K	GJ A6 LARGE STEM GASKET-KALREZ	1 pcs.
68	9614629602	6188K	GJ A6 BASE SCREW GASKET-KALREZ	4 pcs.
69	9614629702	6189K	GJ A6 ROTOR GASKET-KALREZ	1 pcs.
70	9614629802	6190K	GJ VI STATOR GASKET-KALREZ	1 pcs.
11	9614621501	6111	OUTPUT PINION	1 pcs.
16	9614622101	6116	IDLER GEAR	2 pcs.
20	9614622901	6122AS	INPUT PINION ASSEMBLY	1 pcs.
24	9614623401	6126	PLANETARY GEARHEAD LG WASHER	3 pcs.
26	9614623701	6128	PLANETARY GEAR	12 pcs.
27	9614623801	6129	PLANETARY GEAR WASHER	12 pcs.
28	9614623901	6130	PLANETARY GEAR IDLER SHAFT	12 pcs.
30	9614624201	6132	TEE HOUSING CUP	2 pcs.
33	9614624601	6134	NOZZLE HOUSING CUP	2 pcs.
34	9614624901	6137	PLANETARY GEAR CARRIER	1 pcs.
35	9614625001	6138	PLANETARY GEAR CARRIER PINION	1 pcs.
36	9614625101	6140	PLANETARY OUTPUT SHAFT WASHER	1 pcs.
37	9614625201	6141	OUTPUT SHAFT	1 pcs.
54	9614628101	6168	PLANETARY HOUSING SCREW	4 pcs.
55	9614628201	6170	PLANETARY OUTPUT SHAFT WASHER	1 pcs.

8 Parts List and Service Kits

Article no: 9614630002 63AHPMAJEPDMKIT ALFA LAVAL GJ A6 HP MAJOR KIT - EPDM				
Pos. No.	Part No.	Gamajet Part No.	Description	No.
25	9614623601	61273A	PLANETARY GEARHEAD BUSHING	12 pcs.
29	9614624101	61313A	TEE HOUSING BEARING-3A	2 pcs.
31	9614624401	61333AI	NZL HOUSING BEARING-3A-INNER	1 pcs.
32	9614624501	61333AO	NOZZLE HOUSING BEARING-3A	1 pcs.
38	9614625501	61423A	PL OUTPUT SHAFT UPR BSG-3A	1 pcs.
44	9614626401	61483A	IDLER GEAR BUSHING-3A	2 pcs.
45	9614626601	61493A	IDLER SHAFT BUSHING-3A	2 pcs.
49	9614627101	61553AE	NOZZLE O-RING - EPDM-3A	3 pcs.
56	9614628301	61713A	RING GEAR SPACER - 3A	1 pcs.
60	9614628701	6175	GEARHEAD O-RING - EPDM	1 pcs.
61	9614628801	6176	NOZZLE INNER O-RING - EPDM	3 pcs.
62	9614628901	6177	SCREW O-RING - EPDM	10 pcs.
63	9614629101	6181E	GJ A6 STEM GASKET - EPDM	1 pcs.
64	9614629201	6182E	GJ A6 NOSE GASKET - EPDM	1 pcs.
65	9614629301	6185E	GJ A6 COLLAR GASKET-EPDM	1 pcs.
66	9614629401	6186E	GJ A6 LOWER BODY GASKET-EPDM	3 pcs.
67	9614629501	6187E	GJ A6 LARGE STEM GASKET-EPDM	1 pcs.
68	9614629601	6188E	GJ A6 BASE SCREW GASKET-EPDM	4 pcs.
69	9614629701	6189E	GJ A6 ROTOR GASKET-EPDM	1 pcs.
70	9614629801	6190E	GJ VI STATOR GASKET-EPDM	1 pcs.
74	9614624701	6135	TEE HOUSING SEAL	2 pcs.
75	9614624801	6136	NOZZLE HOUSING SEAL	2 pcs.
11	9614621501	6111	OUTPUT PINION	1 pcs.
16	9614622101	6116	IDLER GEAR	2 pcs.
20	9614622901	6122AS	INPUT PINION ASSEMBLY	1 pcs.
24	9614623401	6126	PLANETARY GEARHEAD LG WASHER	3 pcs.
26	9614623701	6128	PLANETARY GEAR	12 pcs.
27	9614623801	6129	PLANETARY GEAR WASHER	12 pcs.
28	9614623901	6130	PLANETARY GEAR IDLER SHAFT	12 pcs.
30	9614624201	6132	TEE HOUSING CUP	2 pcs.
33	9614624601	6134	NOZZLE HOUSING CUP	2 pcs.
34	9614624901	6137	PLANETARY GEAR CARRIER	1 pcs.
35	9614625001	6138	PLANETARY GEAR CARRIER PINION	1 pcs.
36	9614625101	6140	PLANETARY OUTPUT SHAFT WASHER	1 pcs.
37	9614625201	6141	OUTPUT SHAFT	1 pcs.
54	9614628101	6168	PLANETARY HOUSING SCREW	4 pcs.
55	9614628201	6170	PLANETARY OUTPUT SHAFT WASHER	1 pcs.

8 Parts List and Service Kits

Article no: 9614630005 63AHPMAJKALREZ ALFA LAVAL GJ A6 HP MAJOR KIT - KALREZ				
Pos. No.	Part No.	Gamajet Part No.	Description	No.
25	9614623601	61273A	PLANETARY GEARHEAD BUSHING	12 pcs.
29	9614624101	61313A	TEE HOUSING BEARING-3A	2 pcs.
31	9614624401	61333AI	NZL HOUSING BEARING-3A-INNER	1 pcs.
32	9614624501	61333AO	NOZZLE HOUSING BEARING-3A	1 pcs.
74	9614624701	6135	TEE HOUSING SEAL	2 pcs.
75	9614624801	6136	NOZZLE HOUSING SEAL	2 pcs.
38	9614625501	61423A	PL OUTPUT SHAFT UPR BSG-3A	1 pcs.
44	9614626401	61483A	IDLER GEAR BUSHING-3A	2 pcs.
45	9614626601	61493A	IDLER SHAFT BUSHING-3A	2 pcs.
49	9614627103	6155K	NOZZLE O-RING - KALREZ	3 pcs.
56	9614628301	61713A	RING GEAR SPACER - 3A	1 pcs.
60	9614661403	381180	638-Z HOUSING O-RING UPPERII	1 pcs.
61	9614686702	7753K	GJ VII INPUT SHAFT LOWER BEARI	3 pcs.
62	9614677902	8541EP	GJ V GB NS / VIII RS O-RING	10 pcs.
63	9614629102	6181K	GJ A6 STEM GASKET - KALREZ	1 pcs.
64	9614629202	6182K	GJ A6 NOSE GASKET - KALREZ	1 pcs.
65	9614629302	6185K	GJ A6 COLLAR GASKET-KALREZ	1 pcs.
66	9614629402	6186K	GJ A6 LOWER BODY GASKET-KALREZ	3 pcs.
67	9614629502	6187K	GJ A6 LARGE STEM GASKET-KALREZ	1 pcs.
68	9614629602	6188K	GJ A6 BASE SCREW GASKET-KALREZ	4 pcs.
69	9614629702	6189K	GJ A6 ROTOR GASKET-KALREZ	1 pcs.
70	9614629802	6190K	GJ VI STATOR GASKET-KALREZ	1 pcs.
11	9614621501	6111	OUTPUT PINION	1 pcs.
16	9614622101	6116	IDLER GEAR	2 pcs.
20	9614622901	6122AS	INPUT PINION ASSEMBLY	1 pcs.
24	9614623401	6126	PLANETARY GEARHEAD LG WASHER	3 pcs.
26	9614623701	6128	PLANETARY GEAR	12 pcs.
27	9614623801	6129	PLANETARY GEAR WASHER	12 pcs.
28	9614623901	6130	PLANETARY GEAR IDLER SHAFT	12 pcs.
30	9614624201	6132	TEE HOUSING CUP	2 pcs.
33	9614624601	6134	NOZZLE HOUSING CUP	2 pcs.
34	9614624901	6137	PLANETARY GEAR CARRIER	1 pcs.
35	9614625001	6138	PLANETARY GEAR CARRIER PINION	1 pcs.
36	9614625101	6140	PLANETARY OUTPUT SHAFT WASHER	1 pcs.
37	9614625201	6141	OUTPUT SHAFT	1 pcs.
54	9614628101	6168	PLANETARY HOUSING SCREW	4 pcs.
55	9614628201	6170	PLANETARY OUTPUT SHAFT WASHER	1 pcs.

How to contact Alfa Laval Tank Equipment:

For further information, please feel free to contact:

Alfa Laval Tank Equipment

604 Jeffers Circle, Exton, PA 19341 USA

Tel switchboard: +01 610 408 9940 – Fax switchboard: +01 610 408 9945

www.gamajet.com, www.alfalaval.com, customer service: exton@alfalaval.com

contact details for all countries are continually updated on our websites.

© Alfa Laval Corporate AB

This document and its contents is owned by Alfa Laval Corporate AB and protected by laws governing intellectual property and thereto related rights. It is the responsibility of the user of this document to comply with all applicable intellectual property laws. Without limiting any rights related to this document, no part of this document may be copied, reproduced or transmitted in any form or by any means (electronic, mechanical, photocopying, recording, or otherwise), or for any purpose, without the expressed permission of Alfa Laval Corporate AB. Alfa Laval Corporate AB will enforce its rights related to this document to the fullest extent of the law, including the seeking of criminal prosecution.